

OPTIMUMTM OPTIMUMTM TS

ELECTRIC DOWNRIGGERS
Installation Instructions

INTRODUCTION

THANK YOU

Thank you for purchasing a Cannon downrigger. We have designed your new downrigger to be an accurate and reliable tool that will enhance fishing control and improve your ability to catch fish. We hope that you enjoy the use of your new downrigger and enjoy the benefit of controlled depth fishing for years to come by always following safe boating practices and laws wherever you are fishing.

REGISTRATION

Remember to keep your receipt and immediately register your downrigger. A registration card is included with your downrigger or you may complete registration on-line at cannondownriggers.com.

SERIAL NUMBER

Your Cannon 11-character serial number is very important. It helps to determine the specific model and year of manufacture. When contacting Consumer Service or registering your product, you will need to know your product's serial number. We recommend that you write the serial number down in the space provided below so that you have it available for future reference.

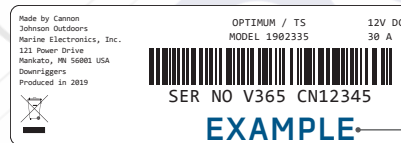
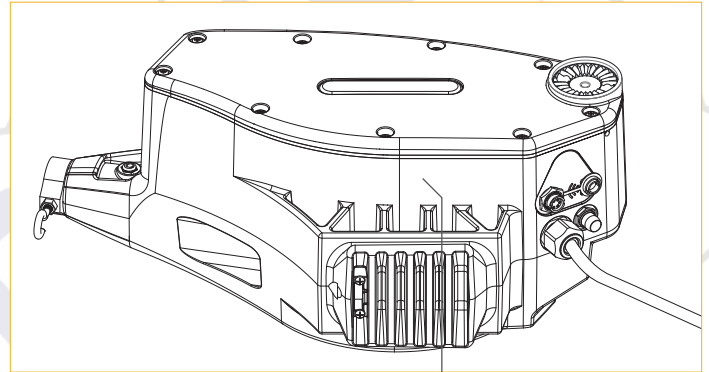

NOTICE: The serial number on your Cannon Optimum downrigger is located on the bottom of the downrigger frame. It can also be found on the About Screen within the Cannon downrigger operating system.

PRODUCT INFORMATION *(For Consumer Reference Only)*

Model: _____

Serial Number: _____

Purchase Date: _____

Store Where Purchased: _____

Made for iPhone® 11 and iPhone X

For updated iOS, Cannon® compatibility, visit cannondownriggers.com.



Use of the Made for Apple badge means that an accessory has been designed to connect specifically to the Apple product(s) identified in the badge, and has been certified by the developer to meet Apple performance standards. Apple is not responsible for the operation of this device or its compliance with safety and regulatory standards. iPhone is a trademark of Apple Inc., registered in the U.S. and other countries. The trademark "iPhone" is used in Japan with a license from Aiphone K.K.

Android™ is a trademark of Google LLC. The Android robot is reproduced or modified from work created and shared by Google and used according to terms described in the Creative Commons 3.0 Attribution License.

SAFETY CONSIDERATIONS

Please thoroughly read this user manual. Follow all instructions and heed all safety and cautionary notices below. Use of this downrigger is only permitted for persons that have read and understood these user instructions. Minors may use this product only under adult supervision. Save these instructions.

WARNING

You are responsible for the safe and prudent operation of your vessel. We have designed your Cannon product to be an accurate and reliable tool that will enhance boat operation and improve your ability to catch fish. This product does not relieve you from the responsibility for safe operation of your boat. You must avoid hazards to navigation and always maintain a permanent watch so you can respond to situations as they develop. You must always be prepared to regain manual control of your boat. Learn to operate your Cannon product in an area free from hazards and obstacles.

WARNING

It is recommended to only use Johnson Outdoors approved accessories with your Cannon. Using non-approved accessories including those used to mount or control your product may cause damage, unexpected operation and injury. Be sure to use the product and all approved accessories, including remotes and/or devices, safely and in a manner directed to avoid accidental or unexpected operation. Keep all factory installed parts in place including motor, electronic and accessory covers, enclosures and guards. Failure to adhere to this warning may affect your warranty.

WARNING

Do not touch the Spool/Reel while the downrigger is in use. Holding or touching it may result in moderate to severe injuries.

KNOW YOUR BOAT

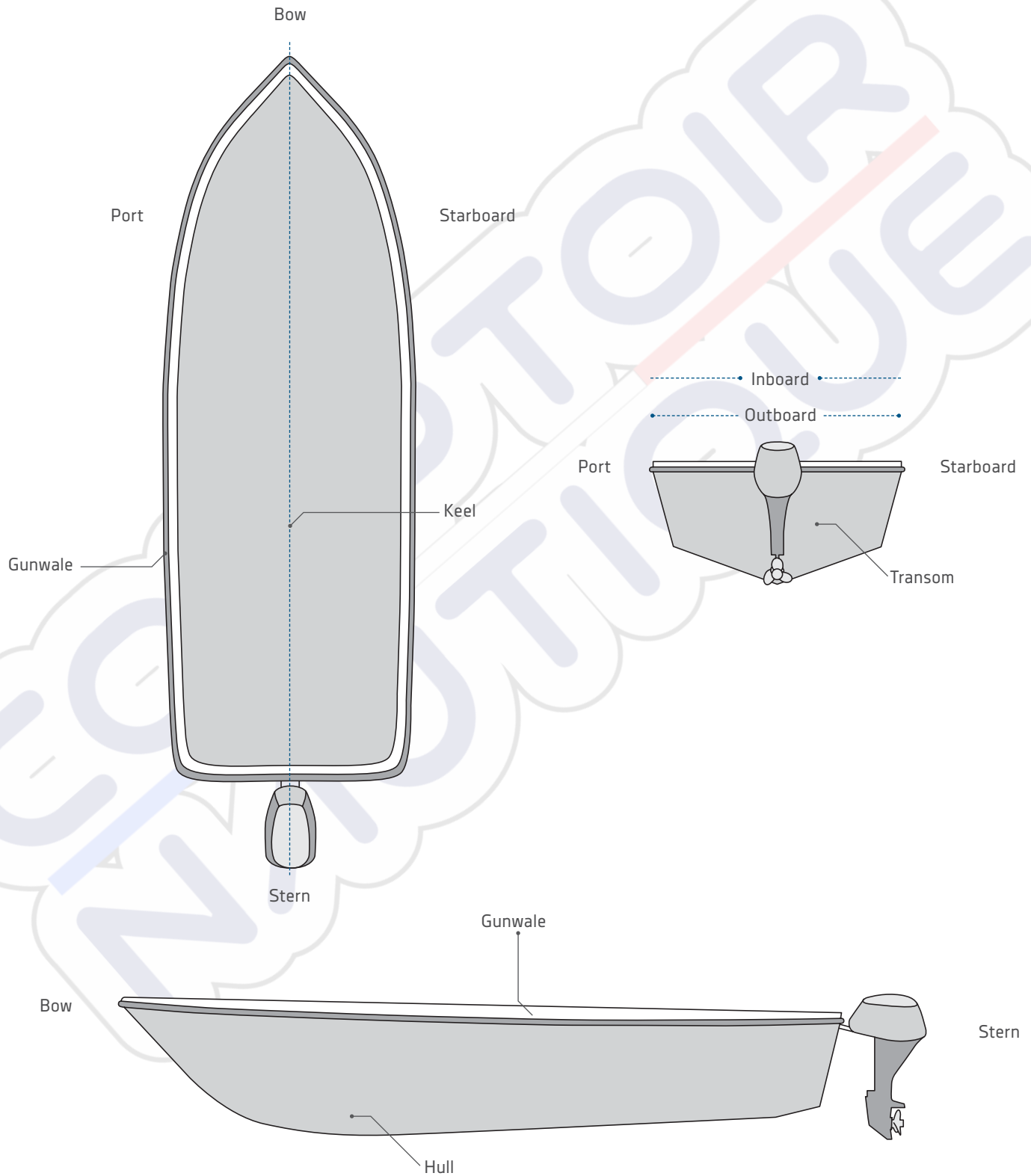

INSTALLATION

INSTALLING THE OPTIMUM™

Your new Cannon Optimum comes with the hardware you'll need to directly install it to the boat. Cannon recommends mounting your downrigger using a deck plate and also offers a variety of accessories to customize your installation. Read these installation instructions to learn more and visit cannondownriggers.com for a full list of accessories. To install the downrigger directly to the boat, please follow the instructions provided in this manual. Please review the parts list, mounting considerations and tools needed for installation prior to getting started. For additional product support, please visit cannondownriggers.com.

INSTALLATION PARTS LIST

Item / Assembly	Part #	Description	Qty.
A	✳	CANNON DOWNRIGGER ASSEMBLY	1
B	3991913	CNN ASSY, SWIVEL BASE	1
C	3991930	ASSY-CNN, MNT BASE	1
D	3392010 ◆	ASSY, BOOM TELESCOPIC, SS *TS*	1
E	2210821	ASY BOOM TELESCOPIC	1
F	3991904 +	ASSY-CNN, ROD HOLDER	1/2
G	3994807	ASSY-BAG, DT PRO/MAG ST	1
H	3994815	BAG ASSY, BOOM END	1
J	2277002	ASY HDW RELEASE UNIVERSAL	2
S	2200109 ◆	SALTWATER RELEASE, OR8 BE *TS*	2
2	9280720	HDW SCR 1/4 20X2 TRUSS HD PHIL	4
4	2371712	WASHER-FLAT 9/32 X 5/8 X 1/16	4
6	2263103	NUT-1/4-20 NYLOCK SS	5
8	9280713	HDW SCR 1/4 20X1 1/2 TRUSS HEA	4
10	3390103	KNOB, SOFT GRIP, CLUTCH	1
12	2263102	NUT-HEX 1/4-20 SS 300SRS	1
14	9040040	HDW BOLT 1/4-20 ROLLEDTHD HOOK	1
16	3393461	SCREW-1/4-20 x 2" SS, PPH	1
18	3397900	BALL HOOK EXTRUSION	1
20	3390101	KNOB-CANNON, SOFT GRIP	2/4
22	2287002	HDW SPRING RELEASE PIN	2/4
24	3392033	TUBE, DUAL AXIS RD HLDR	1/2
26	3394200	ARM, DUAL AXIS-ROD HLDR	1/2
28	2372100	SCREW-#8-18 X 5/8 THD* (SS)	1
30	9100101	CUSHION SLEEVE TERMINATOR	1
32	9100100	CON TERMINATOR	1
34	2200148	ASY SNAP & INSULATOR	1
36	9100620	HDW SNAP SWIVEL 4/0-37 MARLIN	1
K	3990200	ASSY-CNN, BOOM END	1
40	3390910	HANDLE-CRANK, MANUAL	1
42	3397138 ▲	INSTRCT, INSTALL, OPTIMUM	1
44	3397139 ▲	MANUAL DISCLAIMER DWNLOAD INFO	1
46	3397150 ▲	QUICK REF. GUIDE, OPTIMUM	1

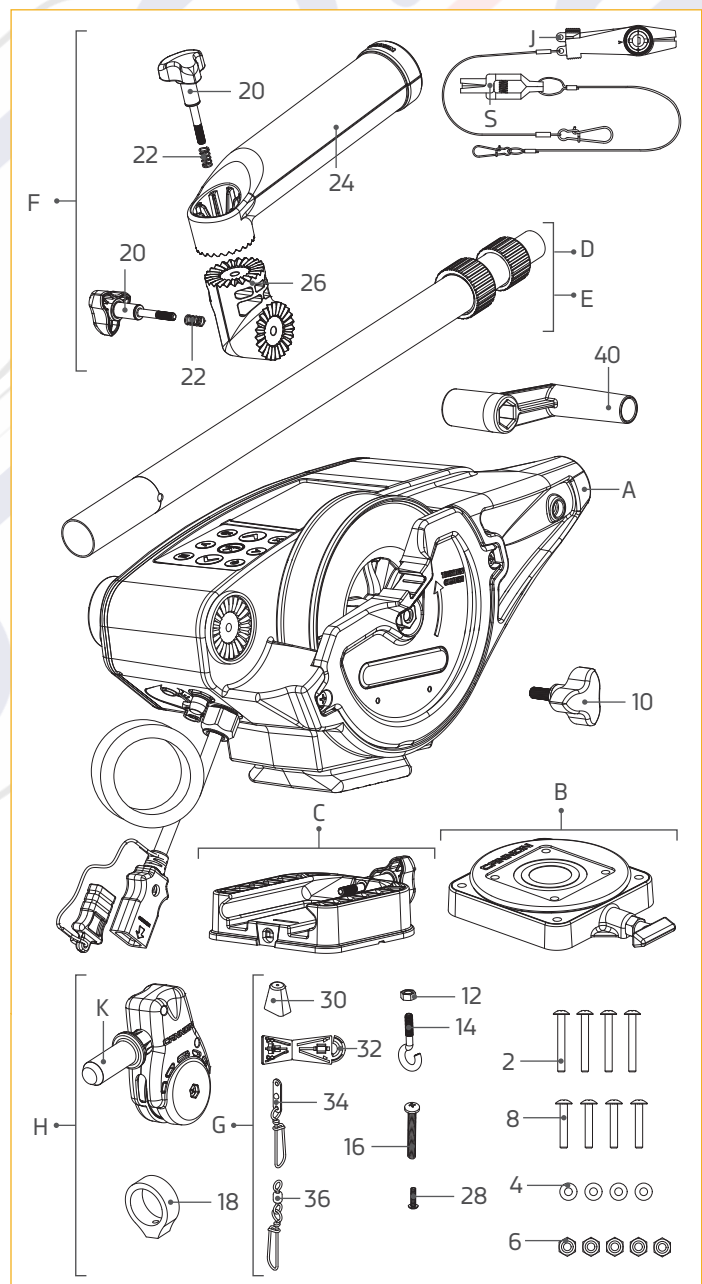

▲ Not shown on Parts Diagram.

✳ This part is included in an assembly and cannot be ordered individually.

+ Only one assembly is available with the tournament Cannon Optimum TS.

◆ Only available with the Optimum TS series downrigger.

INSTALLING THE OPTIMUM



MOUNTING CONSIDERATIONS

Before mounting a Cannon downrigger, please give consideration to the following:

- 1. Clear mounting location** - Choose a good location on your boat to mount your downrigger. Downriggers are mounted to the Gunwale of the boat. Make sure the area under the mounting location is clear to drill holes and install nuts and washers. Make sure that the mounting location is free from cables or wiring and other critical boat structures. The movable parts of the downrigger, such as the telescopic boom should be positioned so that the weight is far enough beyond the edge of the boat so that it and the downrigger will not encounter any obstructions during operation. In some cases, the profile of the Gunwale is raised which may prevent the downrigger from sitting all the way against the face of the Gunwale. It may be necessary to shim or cut away around these areas to securely complete the installation. Mounting accessories are recommended to accommodate difference in mounting locations and mounting situations.
- 2. Operation of the downrigger** - Consider the operation of the downrigger at the selected mounting location. A downrigger should be mounted in a location where it is easy to observe your fishing rod and react quickly to operate the downrigger once there is a fish on the line. There should be enough space to use the downrigger comfortably and with proper ergonomics. It should be easy to reach while still maintaining control of the boat and to retrieve gear. The location of the telescopic boom, weight and rod holder when fully installed should not encounter obstructions. The power cables should reach their intended power source from the mounting location. When installing multiple downriggers, consider the spacing between downriggers units. Mount the downrigger in a location where it is easy to route transducer cables and other downrigger accessory cables and wiring, either to a power source or sonar unit. Make sure that the mounting location does not create a tripping hazard for power cables or accessories used during operation.
- 3. Mounting accessories** - Consider the use of a mounting accessory when installing your downrigger. Consider the location and angle of the rod placement when the downrigger is fully installed on the mounting surface. A deck plate is recommended to provide adequate support and to maximize the capability of the product. Cannon offers a complete line of mounting accessories that allow you to optimize your installation to fit the way you fish. Before making any permanent changes to your boat, consider what accessories might be used in your application. To see the complete line of mounting accessories review the variety of accessories explained in this document or visit cannondownriggers.com.

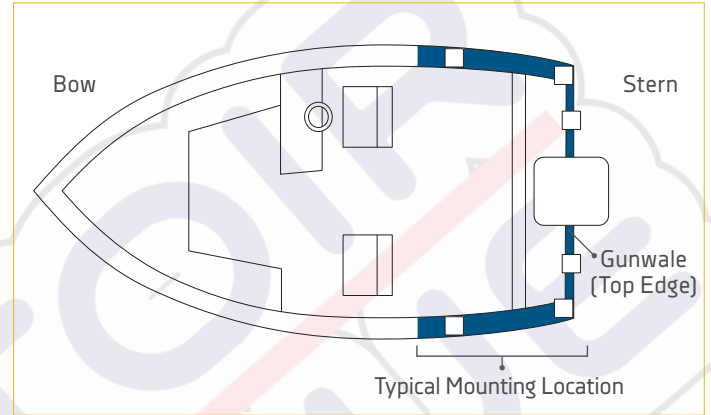

NOTICE: When using the telescopic boom, we strongly recommend the use of a deck plate on all boats to provide adequate stability for the downrigger.

INSTALLING THE OPTIMUM

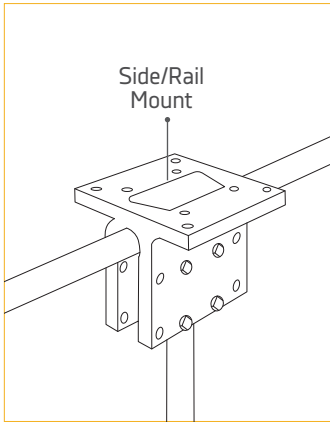

SIDE/RAIL MOUNTS

Can be mounted to a welded T-section. Side/Rail Mounts (Item No. 2250940) can also be used at the two rail section butt joint. In both installations it is recommended to use a non-slip material, such as rubber or a thin wood sheet, between metal surfaces.

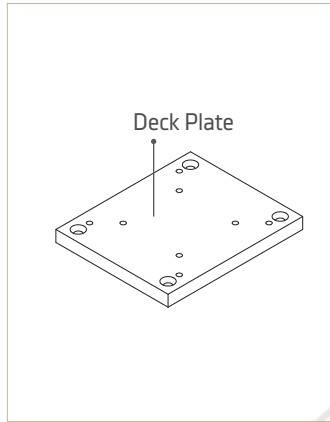

DECK PLATES

Cannon deck plates prevent deflection and add stability to decks. Recommended for attaching the downrigger for initial installation or for mounting accessories. They are necessary to add extra strength to the base material of the boat. Options include Deck Plate (Item No. 2200693).

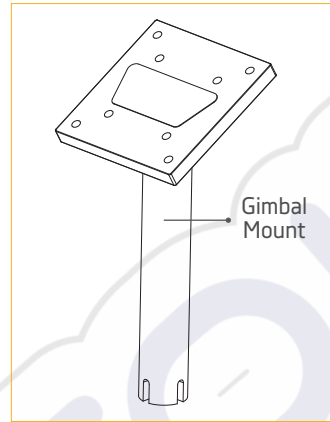

GIMBAL MOUNTS

Designed to fit medium-sized flush mounted rod holders built into the gunwale of larger fishing boats and cruisers. Only sturdy, high quality rod holders should be used for this temporary mounting system. Gimbal mounts are available in 9" or 12" post lengths with Standard (Item No. 2250927 and 2250928) and Stainless Steel options (Item No. 1903005 and 1903006).

TOOLS AND RESOURCES REQUIRED

- 9/32" Drill Bit
- Pencil, Marker or similar Marking Tool
- Drill
- 7/16" Box End Wrench
- Wire Cutters
- Pliers
- #3 Phillips Screw Driver
- Needle Nose Pliers
- Masking tape
- Anti-seize
- A second person to help with the installation

INSTALLING THE BASE



INSTALLATION

INSTALLING THE BASE >

1

Item(s) needed:

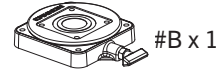
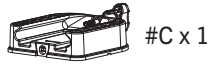
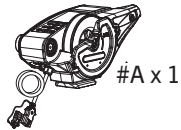

- a. Review the mounting considerations at the beginning of the installation and select a mounting location. Make sure the downrigger is not connected to a power source.

WARNING

Make sure the downrigger is not connected to a power source.

- b. Take the Mounting Base (Assembly #C) and attach it to the Downrigger Assembly (Assembly #A). The Mounting Base is keyed with the bottom of the Downrigger Assembly. The Soft Grip Knob on the Mounting Base screws into a metal plate on the bottom of the Downrigger Assembly. Secure the Mounting Base to the Downrigger Assembly so that the Soft Grip Knob is in the correct position.
- c. In the final Installation, the Mounting Base is installed on the Swivel Base (Assembly #B). If desired, hold the Downrigger Assembly (Assembly #A) with the Swivel Base at the selected mounting location to check fit and function. Use a second person to help with the installation and test to make sure that the downrigger will operate as desired.
- d. Determine if a mounting accessory, such as a recommended deck plate is needed. Refer to the installation instructions included with any mounting accessory and then complete the downrigger installation.

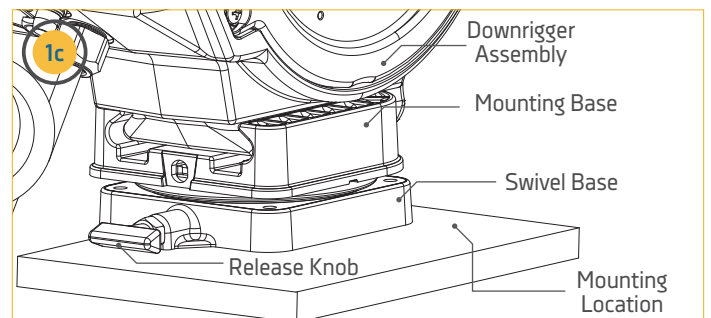
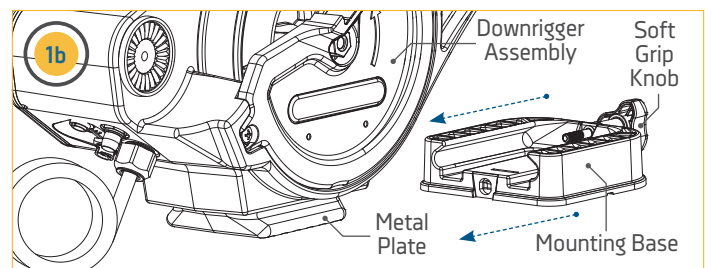
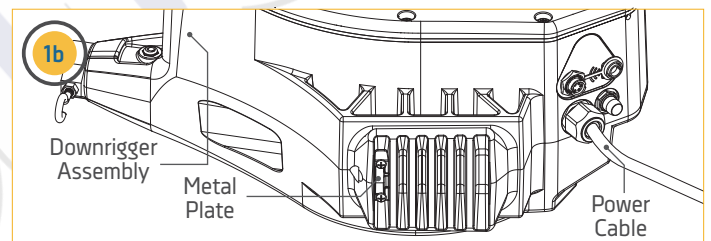
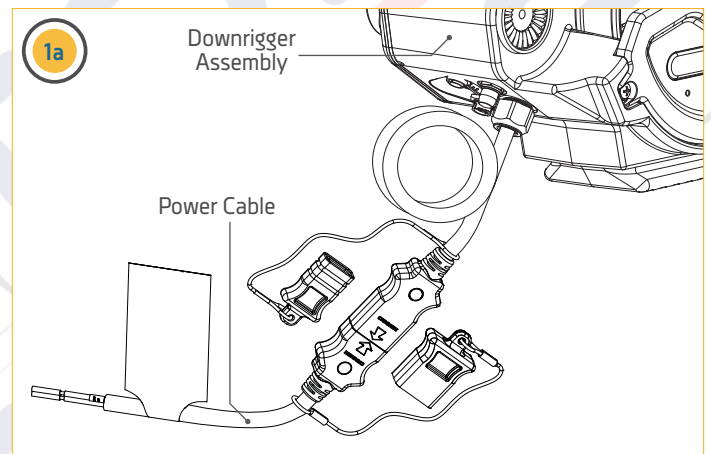

NOTICE: This downrigger weighs approximately 19 lbs. We recommend having a second person help with the installation.

NOTICE: The Release Knob on the Swivel Base can face any direction for your final installation.

INSTALLING THE BASE

2

- e. Once satisfied with the selected location, begin by using the Swivel Base as a mounting template.
- f. Take the Swivel Base and place it at the desired location. Make sure that the Release Knob is orientated in the desired direction and the mounting location is clear to drill holes and can accommodate mounting hardware.
- g. With the Swivel Base in place, use a pencil, marker, or similar marking tool to mark the location of the 4 mounting holes on the mounting location.

NOTICE: When drilling holes, it is helpful to first cover the surface with masking tape. This will help keep the boat surface unmarked and help with cleanup. Cover the surface and then mark the location to drill. Once the pilot holes are drilled remove the masking tape before continuing installation.

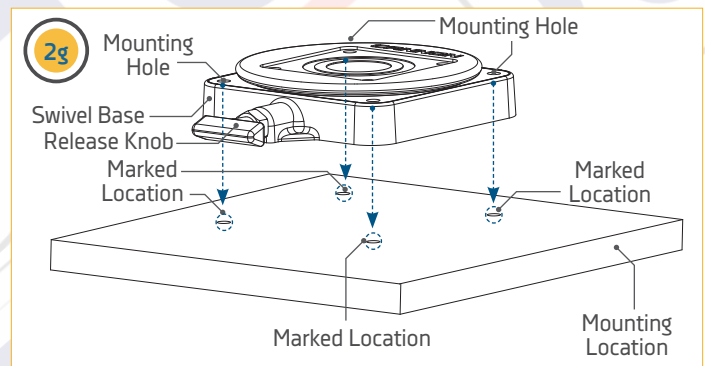
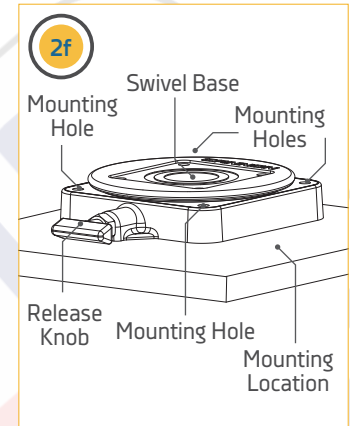
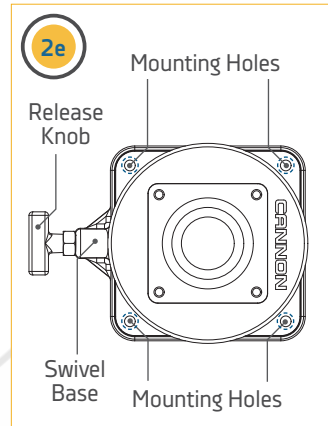

3

- h. With the location marked, set the Swivel Base aside and drill holes, one in each of the four marked locations using a Drill with a 9/32" Drill Bit.
- i. Return the Swivel Base to the mounting location and align it with the four drilled holes. Orientate it back in the desired direction so the mounting holes in the Swivel Base align with the drilled holes in the mounting location and the Release Knob in the desired direction.

NOTICE: Mounting the Swivel Base is optional. If it is preferred to use the Mounting Base only, use the mounting base as a template for drilling holes. To secure the Mounting Base to the deck use four 1/4-20 X 2" Phillips Truss Head Machine Screws (Item # 2) four Flat Washers (Item #4) and four 1/4-20 Nylock Nuts (Item # 6).

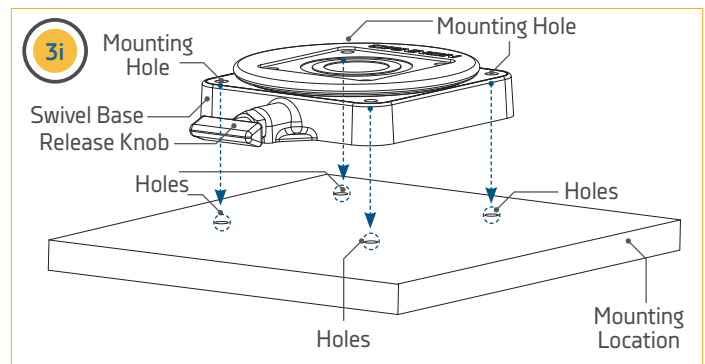
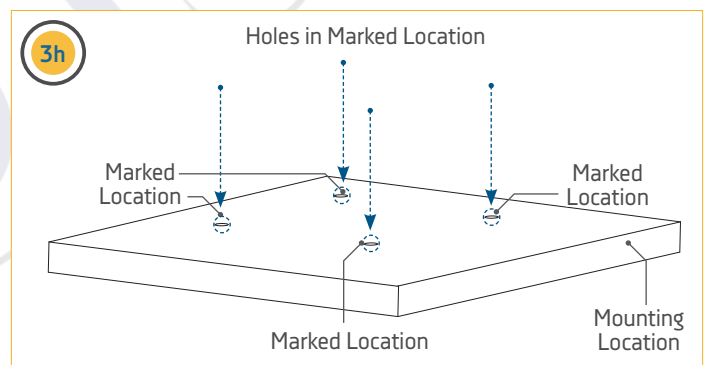

INSTALLING THE BASE

4

Item(s) needed:

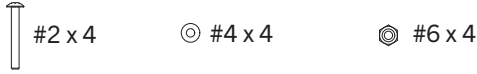

- j. Take four of the 1/4-20 X 2" Phillips Truss Head Machine Screws (Item # 2) and apply anti-seize. Then place one in each of the Mounting Holes. The Truss Screws should pass through the Swivel Base and the drilled holes in the mounting location.
- k. Secure the Truss Screws in place with four Flat Washers (Item #4) and four 1/4-20 Nylock Nuts (Item # 6). Take one Flat Washer and place it on the end of each Truss Screw. Secure each Truss Screw and Flat Washer with Nylock Nuts using a #3 Phillips Screwdriver. Hand tighten, or tighten to 45 ft-lbs. To prevent seizing of the stainless steel hardware, do not use high speed installation tools.

NOTICE: To prevent seizing of the stainless steel hardware, do not use high speed installation tools. Wetting the screws or applying an anti-seize may help prevent seizing.

NOTICE: Consider installing an optional Cannon Lock on the Mounting Base for added security. (Item No. 1903020)

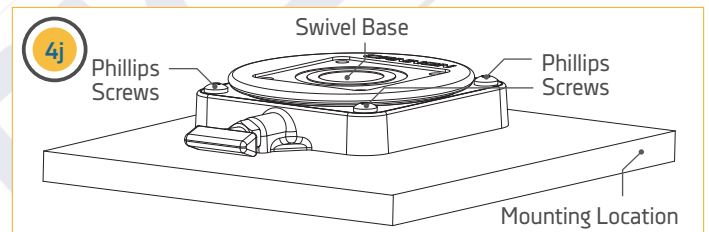
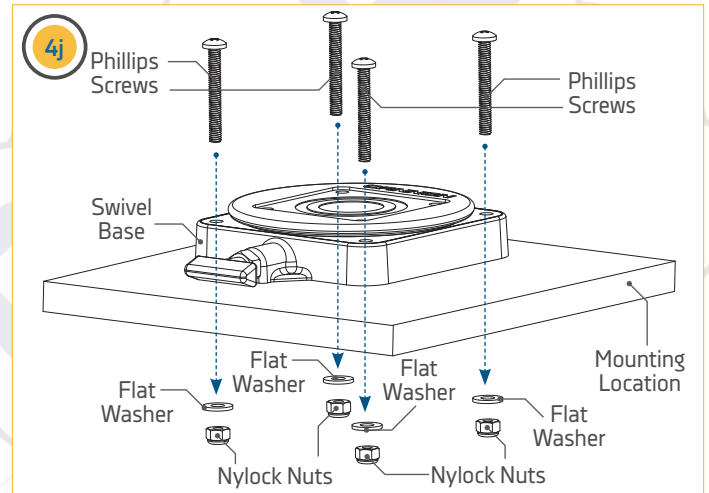

5

Item(s) needed:



- l. The Mounting Base will be installed to the Swivel Base. At the beginning of the installation, the Mounting Base was attached to the Downrigger Assembly. Recall the orientation of the Soft Grip Knob and the orientation of the Downrigger Assembly in its intended installation position.
- m. Remove the Mounting Base from the Downrigger Assembly and place it back on the Swivel Base in the same orientation. The mounting holes in the corners of both the Swivel Base and Mounting Base should align. Take four of the 1/4-20 X 1 1/2" Truss Head Screws (Item # 8) and use them to secure the Mounting Base to the Swivel Base using a Phillips screwdriver.

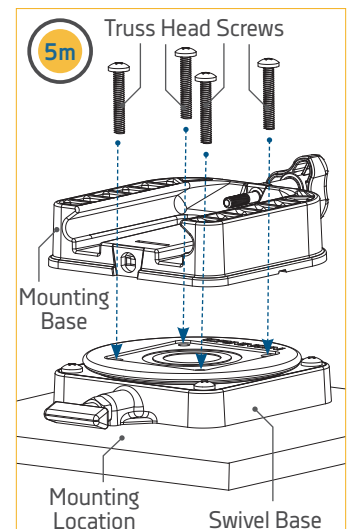
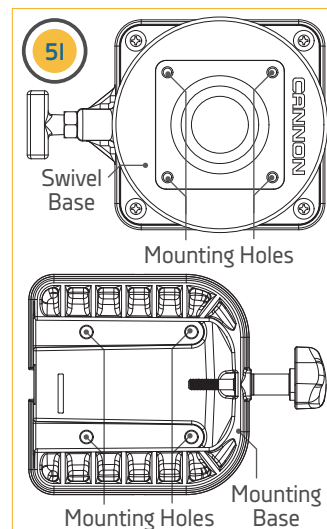

INSTALLING THE CLUTCH KNOB

6

- n. Once the bases are secured together, replace the Downrigger Assembly on the Mounting Base and secure it with the Soft Grip Knob. Hand tighten.

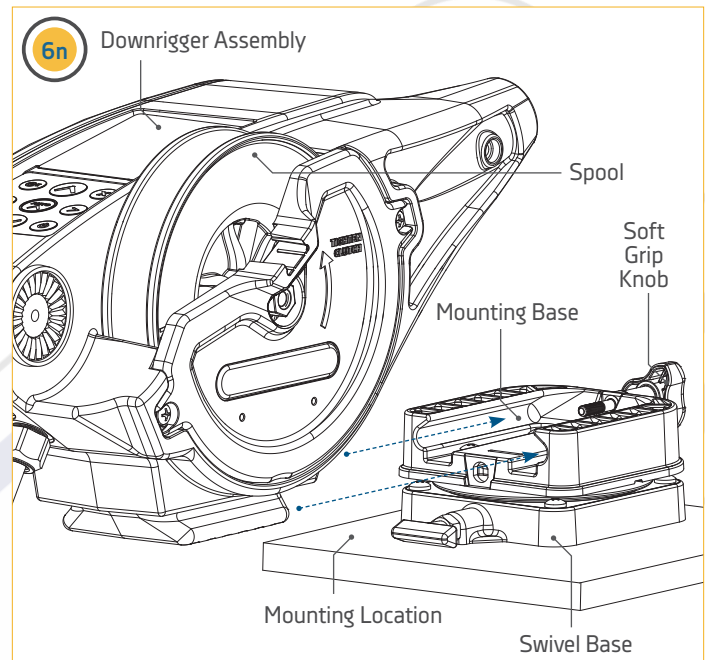

INSTALLING THE CLUTCH KNOB

1

Item(s) needed:



- a. Take the Clutch Knob (Item #10) and install it into the side of the Downrigger Assembly. The Clutch Knob is installed on the side of the downrigger where the Spool is located. When installing the Clutch Knob, insert it into the center of the downrigger spool and turn it counterclockwise to tighten.

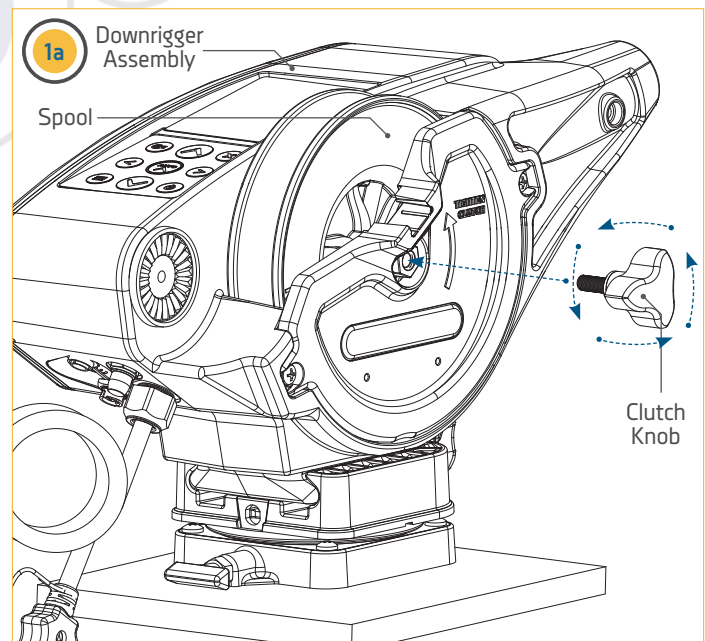

INSTALLING THE TELESCOPIC BOOM



INSTALLING THE TELESCOPIC BOOM >

1

Item(s) needed:

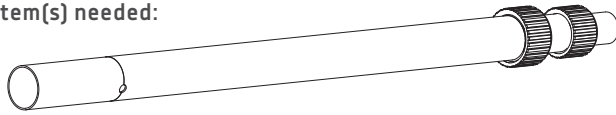

#D x 1 or #E x 1

- a. Take the Telescopic Boom (Assembly #D or Assembly #E) and cut the Cable Tie holding the three tubes of the boom together with a wire cutter or cutting tool. Remove the cut Cable Tie and loosen the Boom Clamps by turning them counterclockwise at the narrow end of the Telescopic Boom.
- b. The Outer Tube that makes up the wider end of the Telescopic Boom has 3 holes used for mounting it to the Downrigger Assembly. The tubes in the Telescopic Boom need to be extended so that the holes used to mount the boom to the downrigger are unobstructed and are free to pass a bolt through.
- c. With the Clamps on the Telescopic Boom loosened, the tubes of the boom can slide apart. Slide the Center Tube about 2 inches out from the original position and then re-tighten the Boom Clamp towards the narrower end of the boom turning clockwise. Slide the Middle Tube about 2 inches out from its original position and tighten the second clamp. Check the opposite end of the boom to see if all three holes on the Outer Tube are clear to pass mounting hardware. If not, re-adjust the Boom Clamps and tubes to expose the mounting holes. Secure the clamps by turning them clockwise so that the tubes do not slide, then set aside.

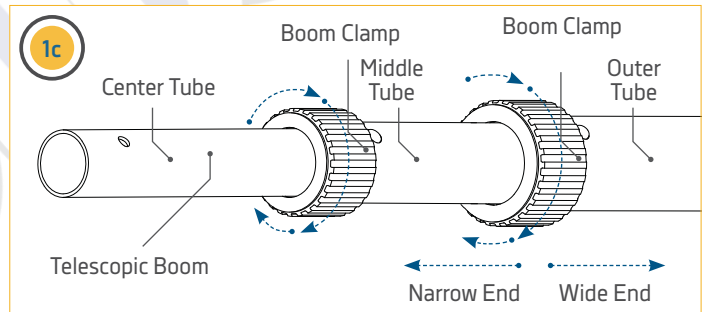
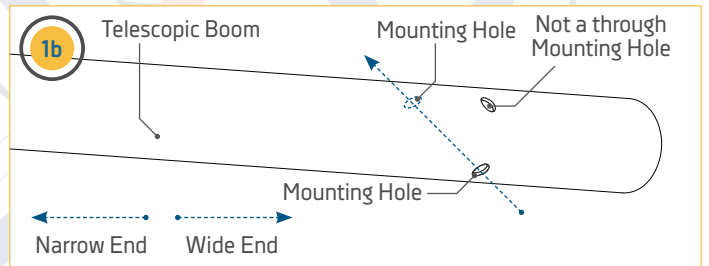
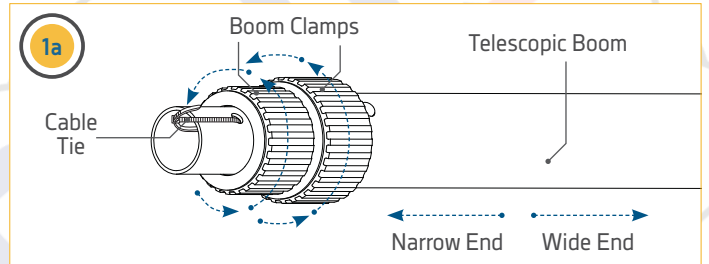

2

Item(s) needed:

 #12 x 1

 #14 x 1

- d. Take the Ball Hook (Item #14) and place the Stainless Steel Hex Nut (Item #12) on it. Turn the Hex Nut far onto the Ball Hook, nearly to the end of the threads. Set the Ball Hook Assembly aside.

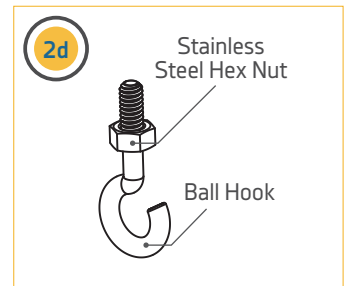
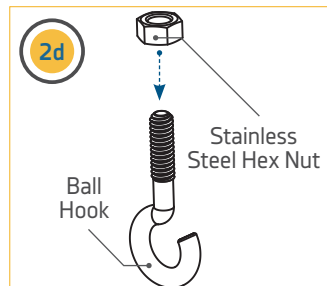

INSTALLING THE TELESCOPIC BOOM

3

Item(s) needed:



- e. Take the Ball Hook Extrusion (Item #18) and place it over the wider end of the Telescopic Boom, opposite the Clamps. At this point on the installation, the Ball Hook Extrusion will slide freely on the Telescopic Boom.
- f. Take the Telescopic Boom with the Ball Hook Extrusion and note the location of the three holes on the wide end of the boom. The two holes across from each other will be used to secure it to the Downrigger Assembly. The two holes are aligned so that hardware can pass straight through to secure it to the Downrigger Assembly. Place it into the end of the Downrigger Assembly and rotate the holes so that the mounting holes in the Boom Assembly are aligned with the mounting holes in the Downrigger Assembly.

NOTICE: If preferred, rotate the Boom Assembly so that the plastic protrusion toward the Narrow End of the boom, next to the Boom Clamp, is rotated downward. This is a cosmetic preference and will not affect the operation of the Boom.

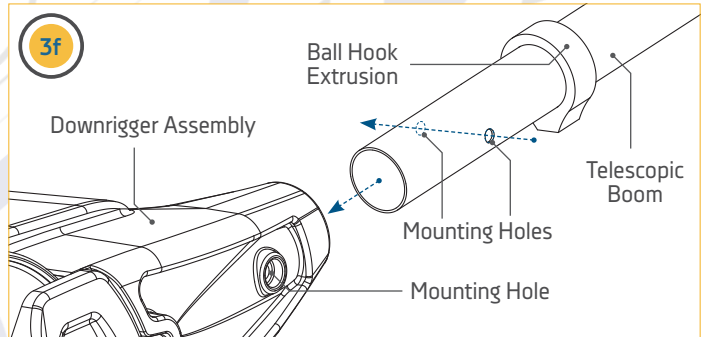
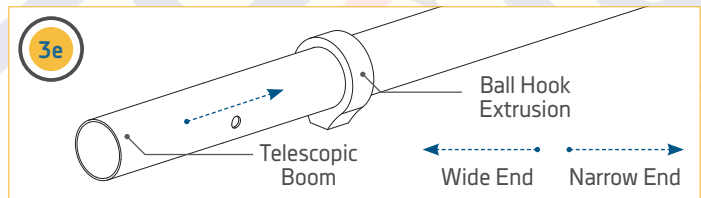
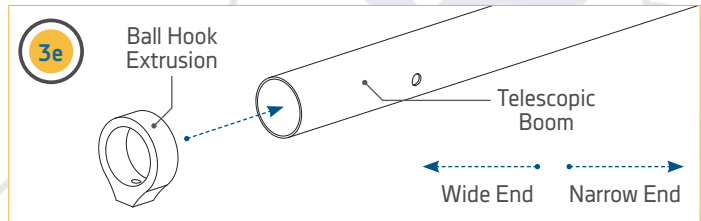

4

Item(s) needed:



- g. The Boom Assembly will be held in place with a Screw and Hex Nut. On the back side of the Downrigger Assembly, on the Motor Side, is a keyed impression for the Nylock Nut. Take the Nylock Nut (Item #6) and press it into the Motor Side of the downrigger, opposite of the Spool Side. The Nylock Nut should be pressed in with the Curved Edge of the Nylock Nut facing outward.

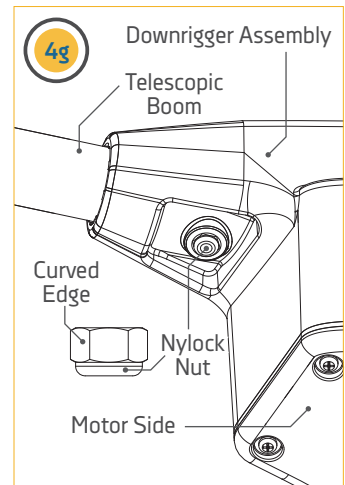
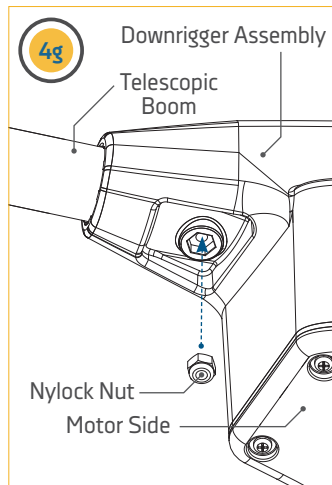

INSTALLING THE TELESCOPIC BOOM

5

Item(s) needed:



- h. The 1/4-20 X 2" Phillips Pan Head Screw (Item #16) will be used to secure the Telescopic Boom to the Downrigger Assembly. The Phillips Pan Head Screw will pass from the spool side of the downrigger to the opposite side of the Downrigger Assembly and through the Boom Assembly. On the Motor Side of the Downrigger Assembly the Phillips Pan Head Screw will be secured into the Hex Nut installed above. Tighten the Phillips Pan Head Screw with a Phillips screwdriver until the end of the bolt is flush with the top of the Nylock Nut on the reverse side of the downrigger.

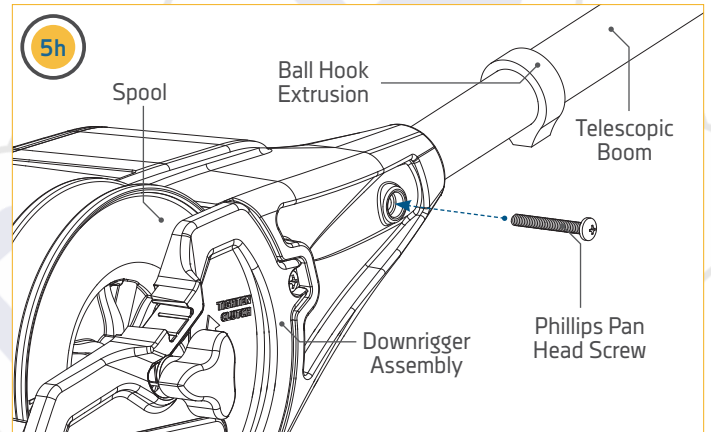

6

- i. With the Telescopic Boom secured to the Downrigger Assembly, slide the Ball Hook Extrusion down on the boom until it is seated against the Downrigger Assembly. Rotate the Ball Hook Extrusion so that the Screw Hole is facing downward.
- j. Attach the Ball Hook Assembly into the Ball Hook Extrusion and hand tighten it until the Ball Hook Assembly has tightly secured the Ball Hook Extrusion in place on the Telescopic Boom. Turn the Ball Hook until the hook is in the desired orientation, turning clockwise.

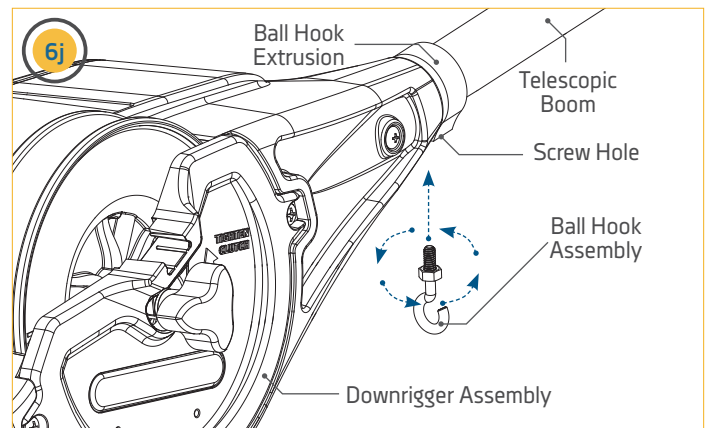
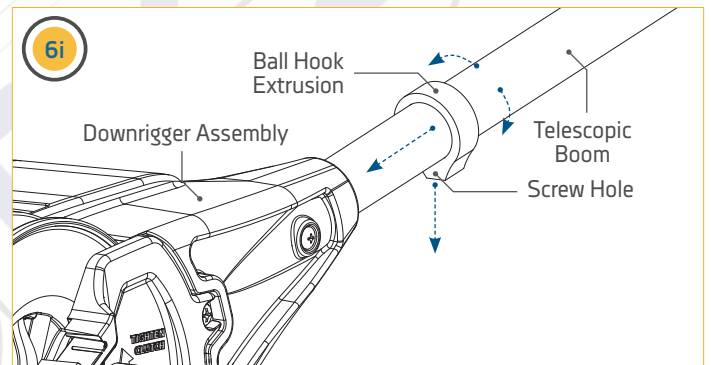

NOTICE: Do not over-tighten the Ball Hook Assembly or denting of the Telescopic Boom is possible.

INSTALLING THE SWIVEL HEAD/BOOM END

7

- k. Secure the orientation of the Ball Hook by turning the Hex Nut on the Ball Hook Assembly until it is seated tightly against the Ball Hook Extrusion with a 7/16" wrench. Hand tighten until secure.

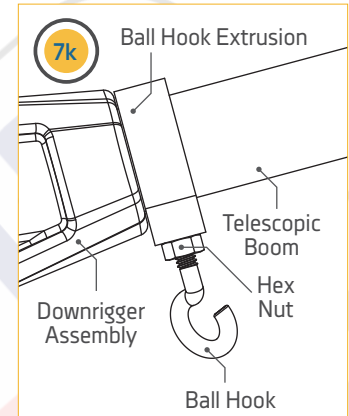
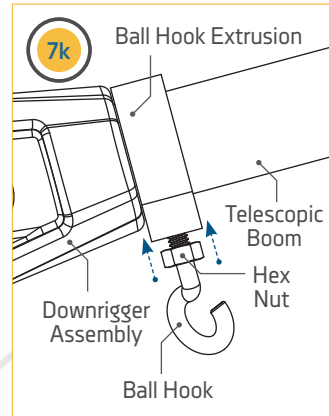

INSTALLING THE SWIVEL HEAD/BOOM END

1

Item(s) needed:

#28 x 1

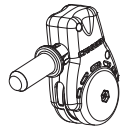

#K x 1

- a. Next install the Boom End (Assembly #K) on the end of the Telescopic Boom. Take the Boom End and find the mounting hole along the shaft. The mounting hole in the Shaft of the Boom End should be aligned with the mounting hole in the Center Tube at the narrow end of the Telescopic Boom.
- b. Once aligned, take the #8-18 X 5/8" Screw (Item #28) and insert it into the end of the Boom Assembly. Secure the screw with a Phillips Head screwdriver by turning clockwise.

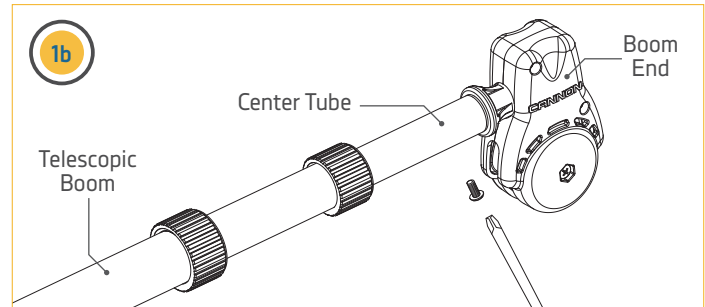
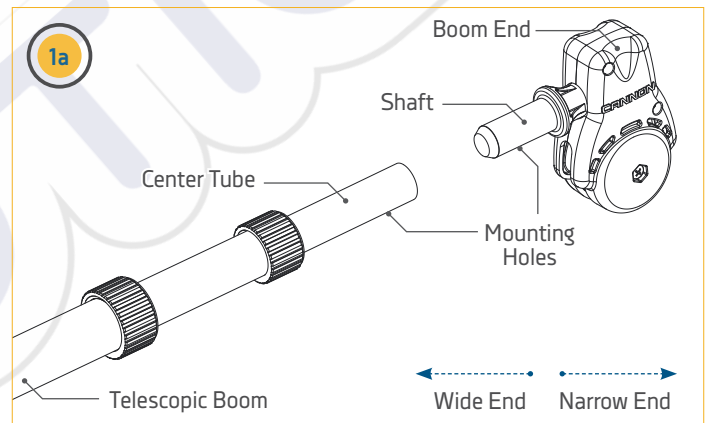

TERMINATING THE DOWNRIGGER LINE



TERMINATING THE DOWNRIGGER LINE >

With the body of the Cannon downrigger installed, the Line on the Spool can be terminated. The downrigger comes standard with stainless steel Line held in place on the Spool with a Rubber Band. During the termination, it is very important to keep tension on the Line to keep it wound tightly around the Spool. To keep tension on the Spool, the Clutch Knob is first installed and then the Line is routed and terminated. Check to determine that the Clutch Knob was installed by referring to the "Installing the Clutch Knob" section of these instructions. If installed, complete the terminating procedure by following these steps:



To watch a video of Terminating the Cannon Downrigger, follow the link on-line at <https://www.youtube.com/watch?v=sQKp73j3aaw>

NOTICE: It may be necessary to have a second person help with terminating the Line.

1

- a. Locate the Rubber Band on the Line. The Rubber Band is securing both the end of the Line tight and holding the Line around the Spool. Keep the Rubber Band secured to the end of the Line, but loosen it from the Spool so that tension can be kept on the Line end by pulling on the Rubber Band. Once it is loose from the Spool, keep tension on the end of the Line by holding the Rubber Band tight.
- b. The Line is wound around the Spool in a counterclockwise direction. Work with the end of the Line the Rubber Band is attached to, so that the end of the Line comes out of the downrigger on the bottom side of the Spool below the Telescopic Boom.

NOTICE: While terminating the Line, it is very important to keep tension on the Line to keep it wound tightly around the Spool.

- c. Pull the Line tight by keeping it secure with the Rubber Band. Slide it through the Bolt Hook Assembly.

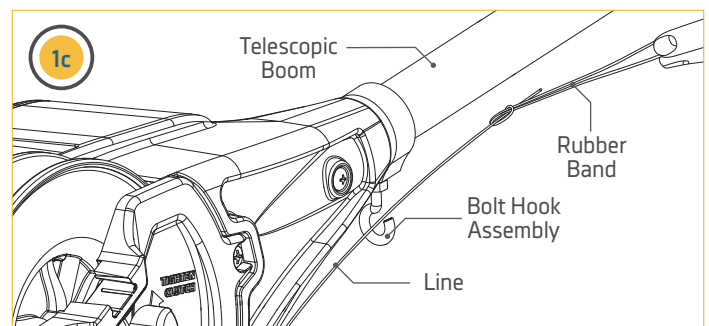
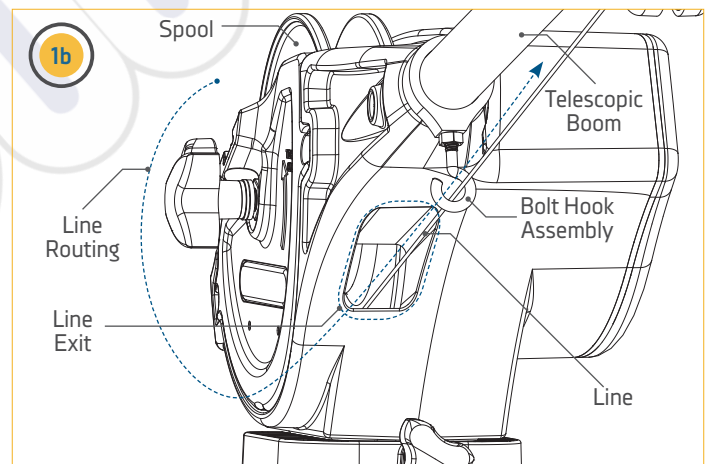
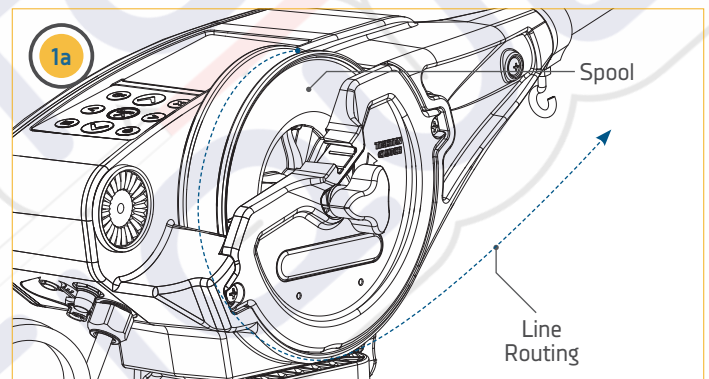

TERMINATING THE DOWNRIGGER LINE

2

- d. The Clutch Knob holds tension on the Spool. Loosen the Clutch Knob on the side of the downrigger by turning it clockwise while keeping tension on the Line. Pull the Line so that there is enough slack to feed the Line through the Pulley.
- e. Feed the Line through the Pulley on the Boom End so that it exits the Pulley on the far end of the Pulley away from the base of the downrigger. Once it passes through the Pulley, pull approximately 2 feet of Line through the Pulley.
- f. Re-tighten the Clutch Knob by turning it counterclockwise and keep tension on the Line.

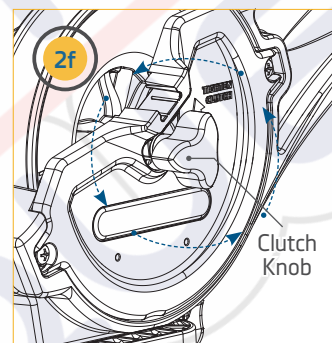
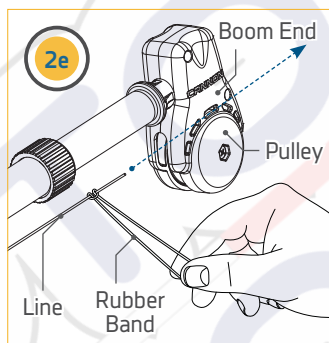
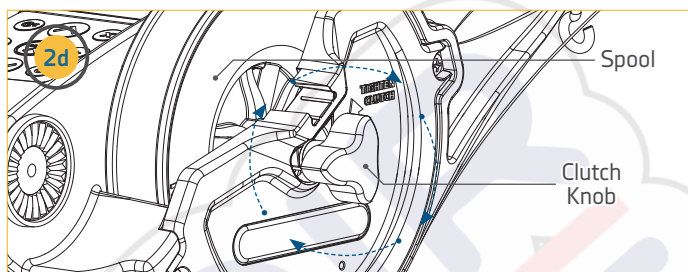

3

Item(s) needed:

 #30 X 1

- g. Have a second person hold the Line just past the downrigger Boom End to keep tension on the Line. Remove the Rubber Band from the end of the Line.
- h. Take a wire cutter and remove any worn or kinked Line.

NOTICE: When routing Line through the Terminator, use only straight Line. Worn or kinked Line can be stressed and may break prematurely when retrieving trolling weights.

- i. Take the Cushion Sleeve Terminator (Item #30) and feed the Line so that the narrower end of the sleeve is threaded first. Thread about a foot of Line through the Cushion Sleeve Terminator.

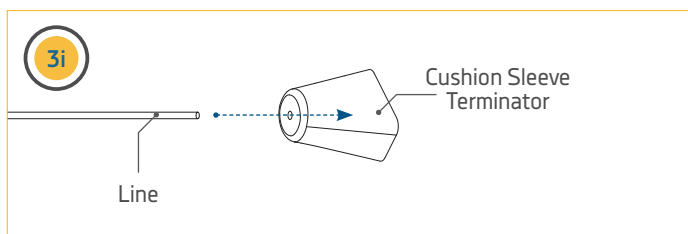
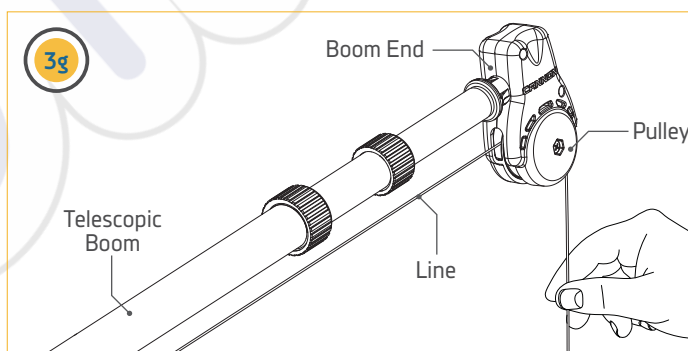

TERMINATING THE DOWNRIGGER LINE

4

Item(s) needed:



#32 X 1



#36 X 1

- j. Take the Snap Swivel (Item #36) and attach it to the hook at the bottom of the Cannon Terminator (Item #32). The Snap Swivel can be attached by inserting the end with the smaller metal loop onto the open end of the Bottom Hook on the Terminator. It may be helpful to use a pair of pliers to link the pieces together.

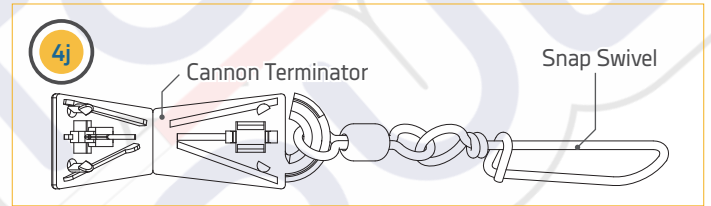
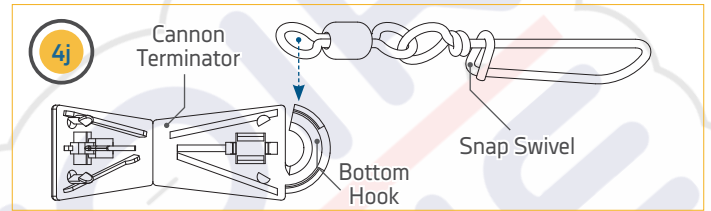

5

- k. With the Snap Swivel attached to the Cannon Terminator, identify the front and back of the Terminator. Also look at the holes along the Top Fold and Bottom Hook of the Terminator. There are three holes along the Bottom Hook of the Terminator, one on each side of the hook and one in the middle. There are also 3 holes along the Top Fold all in close proximity to each other. The Line from the downrigger will be routed through the holes to terminate it.

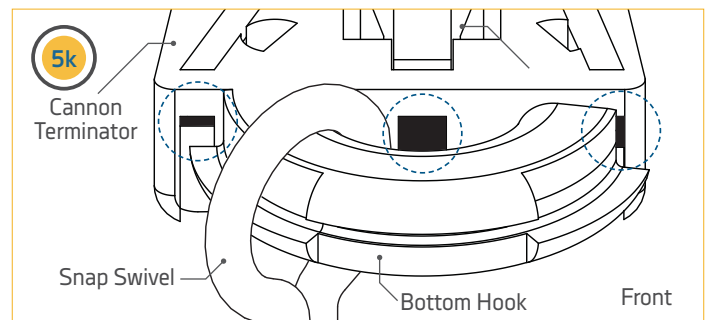
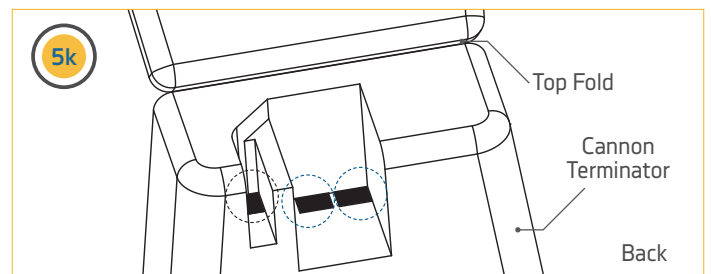
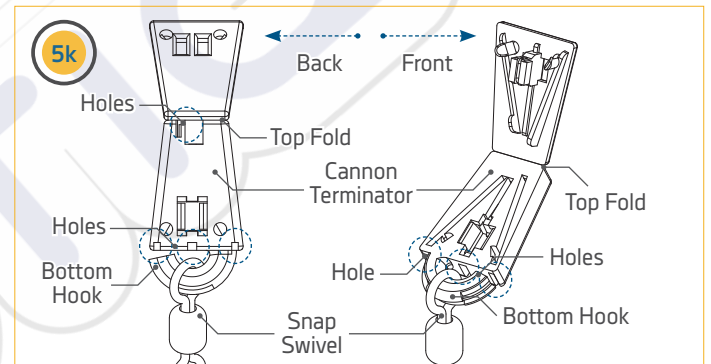

TERMINATING THE DOWNRIGGER LINE

6

- l. Turn the Terminator so that back side is facing toward you. The opening to the Bottom Hook should be on the left. With the Terminator in this orientation, place the freshly trimmed Line into the hole furthest to the right along the top hole so that the Line passes from the back of the Terminator through the hole to the front of the Terminator.
- m. When the Cannon Terminator is turned over facing forward, the Line should follow the Track along the left side of the Terminator to the Bottom Hook. The Line should then be pulled to exit out the bottom along the closed side of the Bottom Hook. Pull about 6 inches of Line from the bottom of the Terminator.
- n. With the Line exiting the bottom of the Terminator, slide the Line along the Bottom Hook so that it passes through the loop of the Snap Swivel linked on the Bottom Hook.
- o. With the Line through the loop on the Snap Swivel, pass it along the Bottom Hook of the Terminator and insert it into the hole in the space at the far end of the Terminator where the Bottom Hook is detached from its base. Pull about 6 inches of the Line through the hole.

NOTICE: When routing the Line through the Terminator, there may be areas where there is slack in the Line. While routing the Line, it is okay for slack to be present. At the end of the termination process, the slack will be pulled tight. Be sure that the slack in the Line does not get kinked, to keep the Line easy to feed through the Terminator.

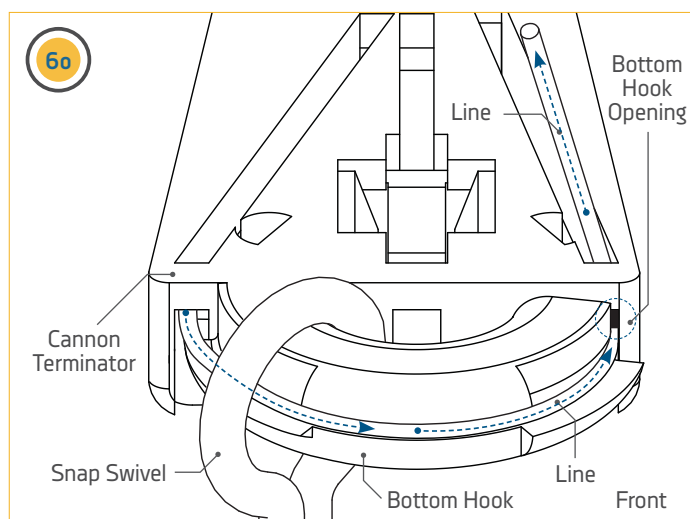
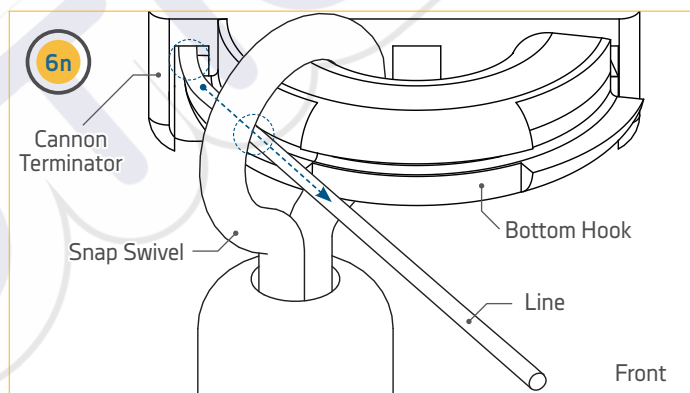
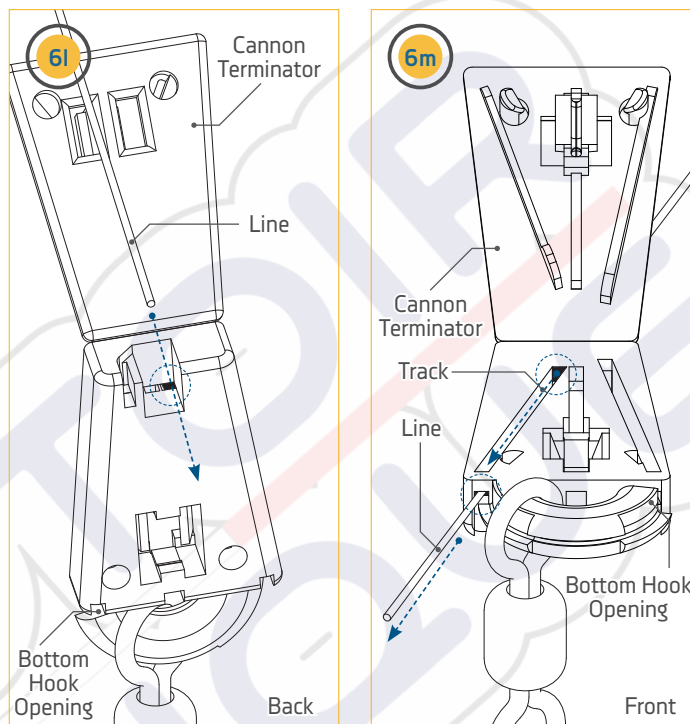

TERMINATING THE DOWNRIGGER LINE

7

- p. With the front of the Cannon Terminator still facing toward you, take the Line and place it along the track along the right side of the Terminator and insert it so that it exits the hole at the far end of the track. The Line will exit the hole towards the back side of the Terminator.
- q. Turn the Terminator over so the back side is facing toward you. Pull about 6 inches of slack through the Terminator.
- r. Take the end of the Line and put it through the hole on the back of the Terminator right next to the hole that the Line was just fed out of. The hole is in the middle of the Terminator and is directly between the hole that the Line just exited and the very first hole that the Line was fed through on the Terminator.

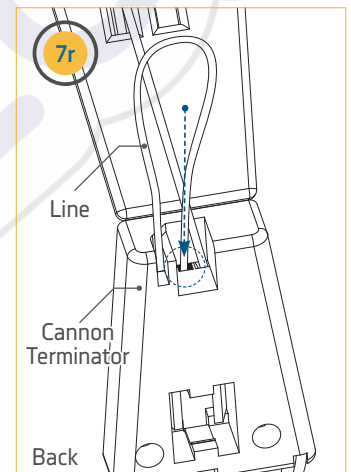
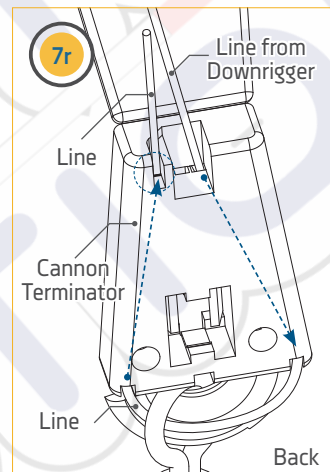
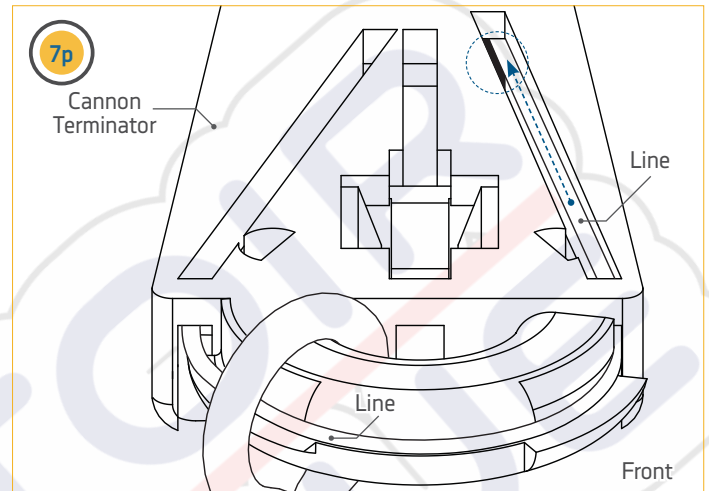

8

- s. Turn the Terminator over so that the front of it is facing towards you. The end of the Line that was just inserted into the back of the Terminator should run along the track in the middle of the Terminator. Feed the Line all the way along this Track so that it exits the hole in the middle of the Terminator along the middle of the Bottom Hook at the end of the Track. The Line should stick out about 1/8 inch from the Terminator along the Bottom Hook.

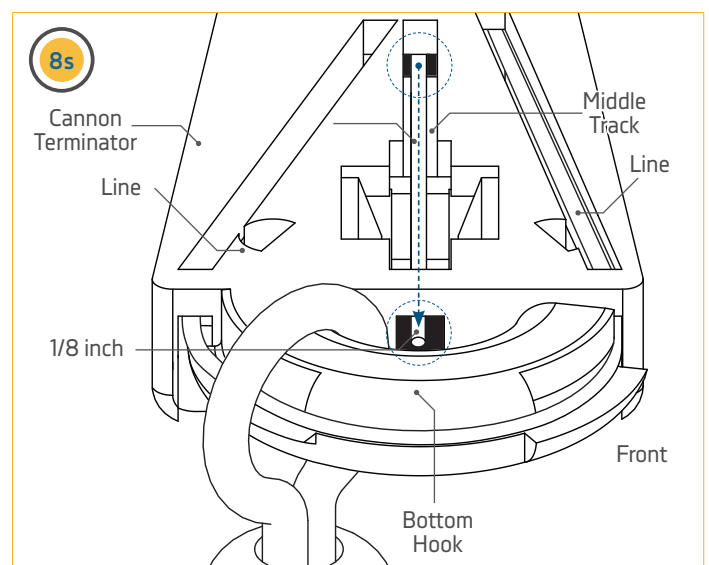

TERMINATING THE DOWNRIGGER LINE

9

- t. With the End of the Line sticking out the final hole by the Bottom Hook, hold the Terminator and squeeze the Line in the middle track to hold it in place. While keeping the end of the Line in place, pull the Line wound through the Terminator in the opposite direction, so that the slack is pulled tight. Use a pliers if necessary to get the Line tight.

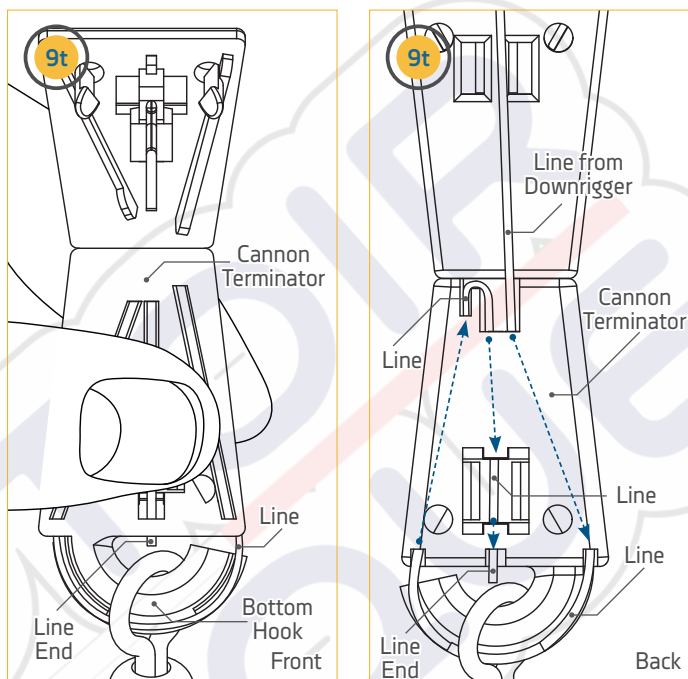

10

- u. With the Line tight, close the Cover of the Terminator so that the Clip in the middle of the top cover captures the Line. Use a Pliers to close the Terminator if necessary. With the Terminator closed, Slide the Cushion Sleeve Terminator securely over the Terminator until it is seated against it. Once fully seated, the downrigger is successfully terminated. A Cannon Weight can then be attached directly to the Snap Swivel.

⚠ CAUTION

Do not overload the downrigger. It is designed to retrieve a maximum of 20 lb. weights only.

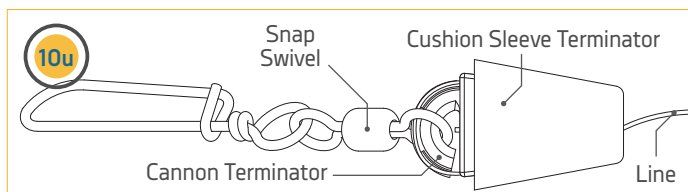
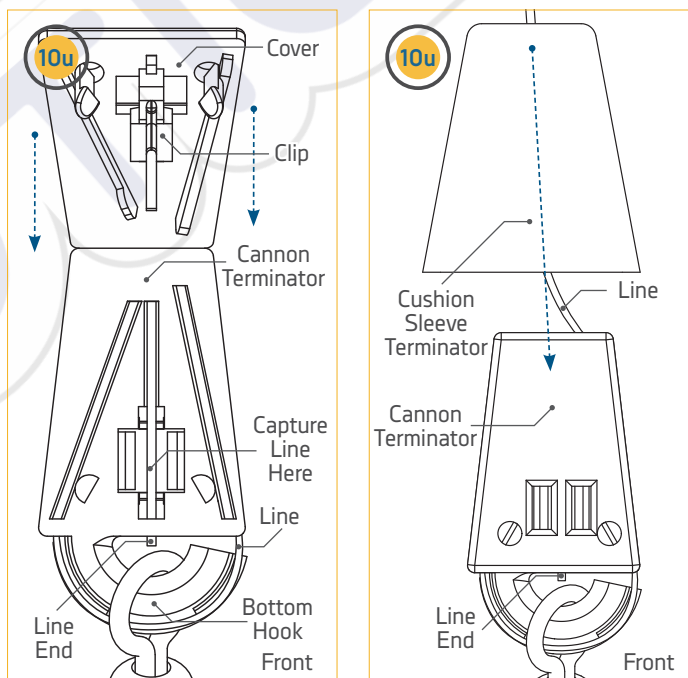

INSTALLING THE REAR MOUNT ROD HOLDER



INSTALLING THE REAR MOUNT ROD HOLDER >

The Cannon Optimum downrigger comes with two Rear Mount Rod Holders, while the Cannon Optimum TS comes with one. The Rod Holder(s) incorporate a two-piece locking tooth design. This allows independent adjustment of the Rod Holder along two axes, which can be easily adjusted every 15° of rotation. The symmetrical design will allow mounting of the Rod Holder on either side of the downrigger or two Rod Holders at the same time. The spring along the shaft of the Soft Grip Knob allows the knob to be loosened and the Rod Holder to be indexed without fully disassembling it. To install, follow the steps below.

NOTICE: The Rod Holder assembly is not covered under warranty when used with tackle above 30 lbs. Equipment placed in the Rod Holders and the loss thereof is the responsibility of the user and is in no way warranted by Johnson Outdoors, Inc. Mounting must be in accordance with the instructions to comply with the product warranty.

CAUTION

The Rod Holder is intended for use of up to 30lb test line only and is not recommended for use with any tackle IGFA (International Game Fish Association) rated higher than 30lb. A safety strap (not included) is recommended for all applications.

1

Item(s) needed:



#20 X 1 or 2



#22 x 1 or 2



#26 x 1 or 2

- a. Depending on the Downrigger, it will come with either one or two Rod Holders. To secure the Rod Holder(s) on the Downrigger Assembly, take one or two Soft Grip Knobs (Item #20) and one or two Spring Releases (Item #22). Place one spring on the end of each Soft Grip Knob.
- b. If the downrigger came with one Rod Holder, determine which side of the downrigger to install the Rod Holder on based on how your downrigger is mounted and how it will be used. Once the location of the Rod Holder is determined, take the Dual Axis Rod Holder Arm (Item #26) and turn it so that the short end of the elbow will be placed against the Downrigger Assembly. The face of the Dual Axis Rod Holder Arm that is installed on the downrigger contains keyed teeth which are matched on the Dual Axis Rod Holder Arm. These keyed teeth will help to hold the position of the knob and help to hold it in place when the position of the holder is changed during use. Secure the Dual Axis Rod Holder Arm with the Soft Grip Knob.

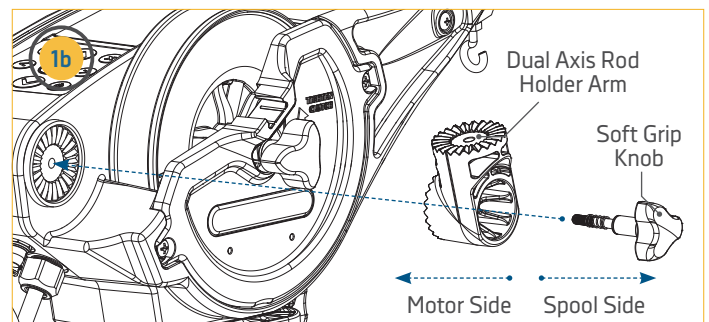
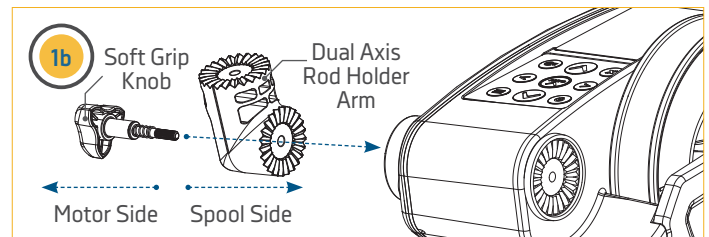
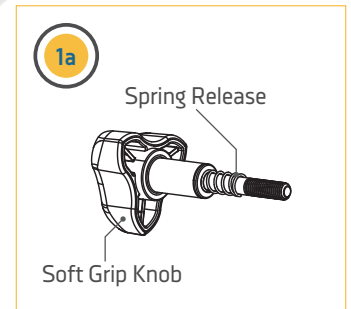
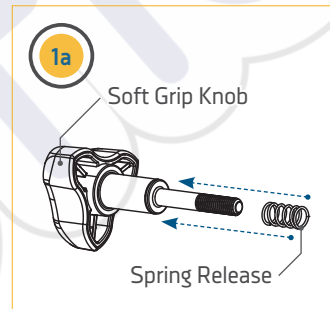

NOTICE: The Tournament Series Optimum downrigger comes with one Rod Holder, the standard Optimum downrigger comes with two Rod Holders.

INSTALLING THE REAR MOUNT ROD HOLDER

2

Item(s) needed:



#20 X 1 or 2

#22 x 1 or 2



#34 X 1

- c. A Soft Grip Knob will be used to secure the Dual Axis Rod Holder Tube to the Arm just installed. Take one or two Soft Grip Knobs (Item #20) and one or two Spring Releases (Item #22). Place one spring on the end of each Soft Grip Knob.
- d. Take the Dual Axis Rod Holder Tube (Item #24) and turn it so that the short end of the piece will be placed against the Dual Axis Rod Holder Arm. The face of the Dual Axis Rod Holder Arm that contains keyed teeth which are matched on the Dual Axis Rod Holder Tube. These keyed teeth will help to hold the position of the knob and help to hold it in place when the position of the holder is changed during use. Secure the Dual Axis Rod Holder Tube with the Soft Grip Knob.
- e. To adjust the direction of the Dual Axis Rod Holder Arm or tube, loosen the Soft Grip Knob and rotate in the desired direction. Then re-tighten the Soft Grip Knob to secure in place.

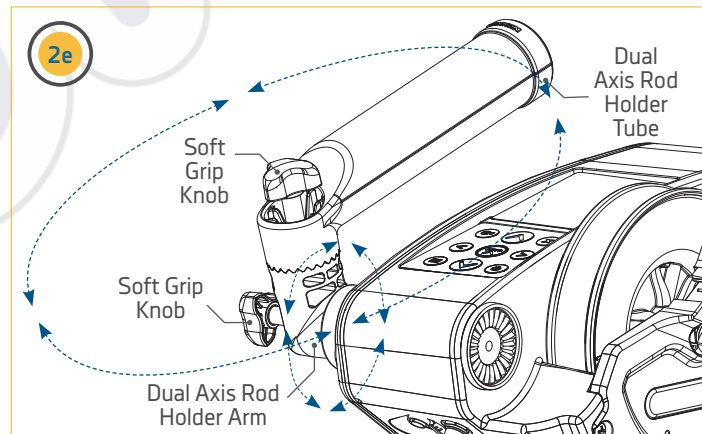
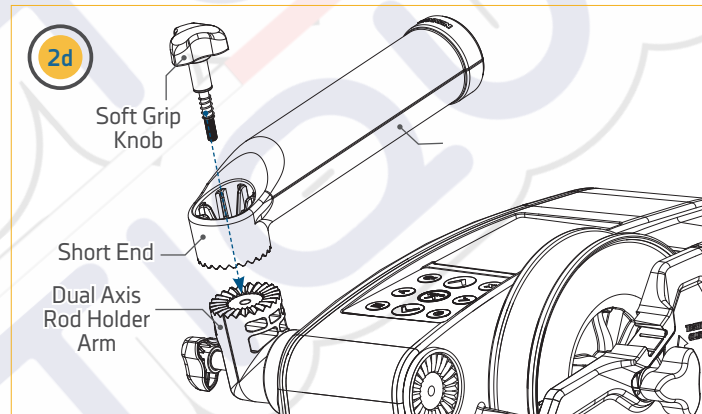
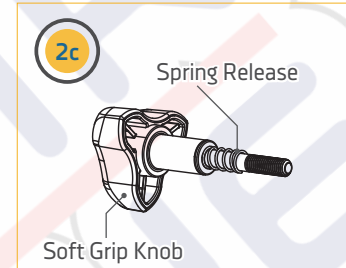
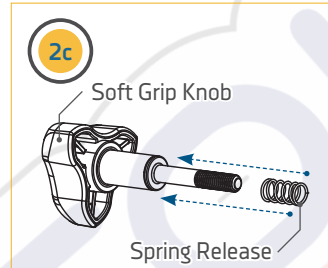

NOTICE: The Soft Grip Knobs and Spring Releases will be inside the Dual Axis Rod Holder Tube.

WIRING THE DOWNRIGGER

RIGGING & INSTALLATION GUIDELINES

For safety and compliance reasons, we recommend that you follow American Boat and Yacht Council (ABYC) standards when rigging your boat. Altering boat wiring should be completed by a qualified marine technician. The following specifications are for general guidelines only:

CAUTION

These guidelines apply to general rigging to support your Cannon product. Powering multiple downriggers or additional electrical devices from the same power circuit may impact the recommended conductor gauge and circuit breaker size. If you are using wire longer than that provided with your unit, follow the conductor gauge and circuit breaker sizing table below. If your wire extension length is more than 30 feet, we recommend that you contact a qualified marine technician.

CAUTION

Please read the following information before connecting your downrigger to a battery in order to avoid damaging your product and/or voiding your warranty.

CONDUCTOR GAUGE AND CIRCUIT BREAKER SIZING TABLE

This conductor and circuit breaker sizing table is only valid for the following assumptions:

1. No more than 2 conductors are bundled together inside of a sheath or conduit outside of engine spaces.
2. Each conductor has 105° C temp rated insulation.
3. No more than 5% voltage drop allowed at full motor power based on published product power requirements.

Fuse/Breaker Specifications	Wire Specifications		
30 Amp, 32 Volt, Waterproof, Fast Blow	10 Gauge	8 Gauge	6 Gauge
	0-10 feet	11-15 feet	16-20 feet
	0-3 meters	3-4.5 meters	4.5-6 meters

CAUTION

An over-current protection device (circuit breaker or fuse) must be used. Coast Guard requirements dictate that each ungrounded current-carrying conductor must be protected by a manually reset, trip-free circuit breaker or fuse. The type (voltage and current rating) of the fuse or circuit breaker must be sized accordingly to the Cannon downrigger used.

WIRING THE DOWNRIGGER

RECOMMENDATIONS FOR MAINTAINING BOAT'S ELECTRICAL CONDITION

Whenever a boat is in water, various submerged parts interact to create weak electrical currents. These weak electrical currents should be controlled to extend the life of the boat's metal parts and ensure a good fish catching environment. In order for the Positive Ion Control and Short Stop (PIC) on your downrigger to work correctly, it is important to make sure your boat is properly set up before installing your downrigger. For full details on how the Positive Ion Control system works, see the "Positive Ion Control" section of the Owner's Manual.

- If the zinc sacrificial anodes on your boat and on the outboard/outdrive are more than half dissolved, it is recommended that they be replaced. Clean anodes on a regular basis with a non-corrosive brush.
- Any coating of slime or growth on the boat should be cleaned off.
- All metal parts including the hull (if metal) should be interconnected by a grounding wire. This includes motor shafts, outdrives, and through hull fittings. This will ensure that the boat is properly grounded to the water and allow Positive Ion Control and Short Stop to work correctly.
- The line on your downrigger should be replaced every 2 years. Etching of the line can weaken it physically and electrically.
- The use of Cannon coated weights and the snap assembly with the insulator will help insulate the weight from the positively charged line.

NOTICE: To ensure proper operation of your downrigger, ground the downrigger battery to your boat's electrical system's ground. Always check to see if your boat is properly grounded first. Malfunctions with the Positive Ion Control, communication between units, or loss of operation result from faulty grounding.

ELECTRICAL SPECIFICATIONS & WIRING INSTRUCTIONS

The downrigger is rated at 30 amps (full load), 12 volts DC and is protected by a 25 amp manual reset circuit breaker (located under motor housing). Be sure to measure the battery voltage of your boat.

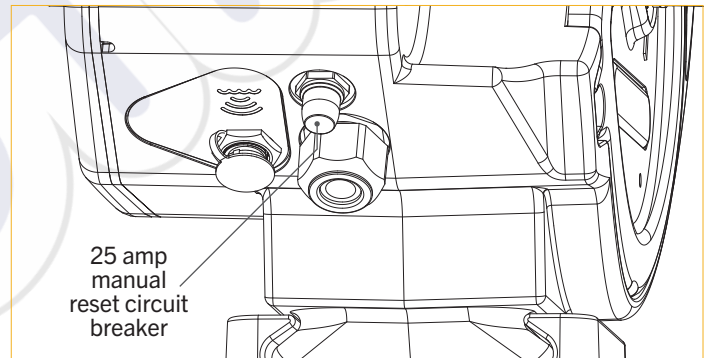

⚠ WARNING

Do not run this downrigger on a 24 volt or higher battery system. This will damage the unit and void your warranty. Only connect your downrigger to a 12 volt battery system.

⚠ WARNING

It is strongly recommended to power your downrigger with a battery capable of providing high currents for an extended period of time. Only run a downrigger from a Starter battery if it is recharged by an alternator while the downrigger is running.

⚠ WARNING

Never connect the (+) and the (-) terminals of the same battery together. Take care that no metal object can fall onto the battery and short the terminals. This would immediately lead to a short and extreme fire danger.

WIRING THE DOWNRIGGER

CONNECTING TO THE BATTERY

It is strongly recommended that a fuse or manual reset circuit breaker be installed within 7 inches from the battery on the positive lead of the power cable. In addition, you may also connect the downrigger to a battery selector switch. It is strongly recommended to power your downrigger with a Deep-Cycle marine battery. Only run a downrigger from a Starter battery if it is recharged by an alternator while the downrigger is running.

1. Make sure that the downrigger is powered "off" or the Quick Connect Plug on the downrigger Power Cable is disconnected.
2. Connect positive (+) red lead to positive (+) battery terminal.
3. Connect negative (-) black lead to negative (-) battery terminal.
4. Reconnect the Quick Connect Plug when ready to use the downrigger.

NOTICE: Control degradation of the power cables and limit corrosion by using anti-oxidant gel on all connections. Do not use wing nuts.

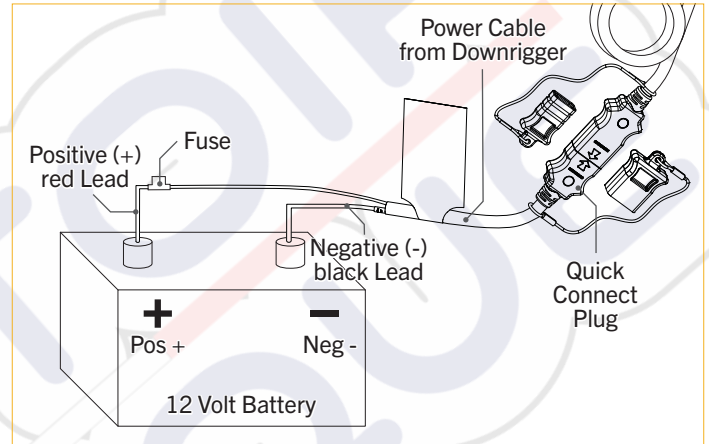

⚠ CAUTION

Refer to "Conductor Gauge and Circuit Breaker Sizing Table" in the previous section to find the appropriate circuit breaker or fuse for your downrigger.

⚠ WARNING

For safety reasons, disconnect the downrigger from the battery when the downrigger is not in use or while the battery/batteries are being charged. If installing a leadwire plug, observe proper polarity and follow instructions in your boat owner's manual. Keep leadwire connections tight and solid to battery terminals. Locate battery in a ventilated compartment.

POWERING MULTIPLE DOWNRIGGERS

When operating multiple downriggers, run a maximum of 2 downriggers per dedicated 12 volt battery. Follow the instructions from the "Connecting to the Battery" section of these Installation Instructions. Repeat the directions for each downrigger.

NOTICE: Use the Quick Connect Plug to remove power from the downrigger without touching the battery.

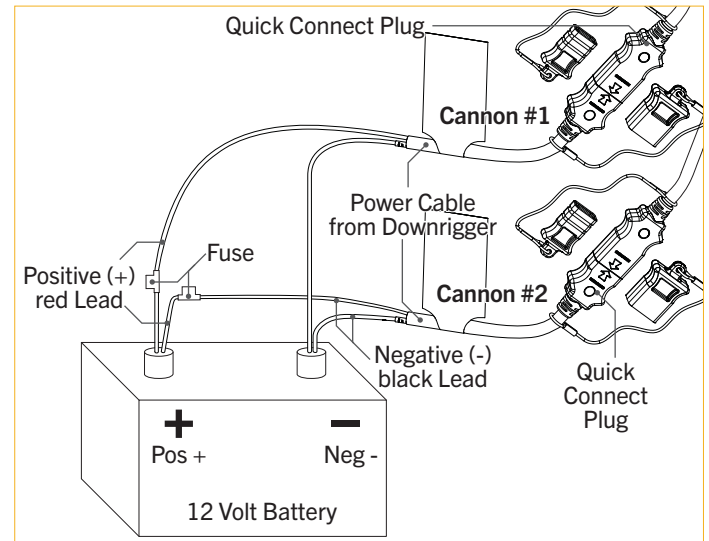

ADDITIONAL CONSIDERATIONS

ADDITIONAL ACCESSORIES CONNECTED TO DOWNRIGGER BATTERIES >

Significant damage to your Cannon downrigger, your boat electronics, and your boat can occur if incorrect connections are made between your downrigger batteries and other battery systems. It is recommended to use an exclusive battery system for your downrigger. Where possible, accessories should be connected to a separate battery system. Radios and sonar units should not be connected to any downrigger battery systems as interference from the downrigger is unavoidable. If connecting any additional accessories to any downrigger battery system, or making connections between the downrigger batteries and other battery systems on the boat, be sure to carefully observe the information below.

The negative (-) connection of an accessory device must be connected to the negative terminal of the same battery that the downrigger negative lead connects to. Connecting to any other downrigger battery will input positive voltage into the "ground" of that accessory, which can cause excess corrosion. Any damage caused by incorrect connections between battery systems will not be covered under warranty.

AUTOMATIC JUMP START SYSTEMS AND SELECTOR SWITCHES >

Automatic jump start systems and selector switches tie the negatives of the connected batteries together. Please see a qualified marine technician if installing your Cannon downrigger with one of these systems or a selector switch.

SELECTING THE CORRECT BATTERIES >

The downrigger will operate with any lead acid deep cycle marine or Lithium 12 volt battery/batteries. For best results, use a deep cycle marine battery. Maintain battery at full charge. Proper care will ensure having battery power when you need it, and will significantly improve the battery life. Failure to recharge lead-acid batteries (within 12-24 hours) is the leading cause of premature battery failure.

Use a multi-stage charger to avoid overcharging. We offer a wide selection of chargers to fit your charging needs. If you are using a crank battery to start a gasoline outboard, we recommend that you use a separate deep cycle marine battery/batteries for your Cannon downrigger.

SETUP GUIDE

SETTING UP THE OPTIMUM™









When powering the downrigger "on" for the first time, the Color LCD will bring up a Setup Guide. In order to follow through the Setup Guide, first become familiar with the downrigger keypad. When comfortable with the keypad, follow through the Setup Guide to customize downrigger settings before beginning to use the downrigger for fishing. The Setup Guide will also appear the first time that the downrigger is powered "on" after the defaults have been restored.

DOWNRIGGER KEYPAD







- POWER** - When the downrigger is "off", press to turn the downrigger "on". When the downrigger is "on", a quick press will open the Power Menu or pressing and holding for 3 seconds will power the downrigger "off".
- UP** - When all menus are closed, press to control the Spool to bring the weight up and the line in. The weight will continue to come up until the button is released or the line counter reaches "0". If the downrigger is currently moving the line when pressed, it will cancel the action. When any menu is open, pressing it will cycle up through the menu options. If the menu reaches the top of the list it will move to the bottom and continue to move up the options.
- AUTO UP** - Single press to automatically bring the weight up and the line in at speed 5. The weight will continue to come up until the line counter reaches 0 or Short Stop is engaged even when the button is released. Single press and hold to bring the weight up for all downriggers in the Network. Use the Right button to confirm the Auto Up All selection. The weights for all downriggers will continue to come up following the same controls for a single downrigger.
- DOWN** - When all menus are closed, press to control the Spool to send the weight down and the line out. The weight will continue to go down until the button is released or the line is completely let out. If the downrigger is currently moving the line when pressed, it will cancel the action. When any menu is open, pressing will cycle down through the menu options. If the menu reaches the bottom of the list it will move to the top and continue to move down the options.
- LEFT** - Press to make selections, adjustments to menus or change Views.
- RIGHT** - Press to make selections, adjustments to menus or change Views. When menu selections are finalized, press to close the menu.
- MENU** - When the Color LCD has any one of the Views open on the screen, a single press will open the Quick Menu for the View displayed. Double press from any View to open the Settings Menu. If the Settings Menu is open, pressing again will close the menu. If a Quick Menu is open, a single press will open the Settings Menu.
- PRESET DEPTHS** - Press to open the Preset Depths Menu and to access Last Depth Recall.
- EXIT** - Press to exit or close menus. Returns Color LCD to the last screen or View.



SETUP GUIDE



The Setup Guide is a set of menus that help the user select settings to help with downrigger operation. All of the options in the Setup Guide can be accessed in menus within the downrigger if preferences change after initial setup. The Setup Guide will first bring up a menu that gives the user the option to select Language, Battery Alarm, Temperature, Depth/Distance and Speed. Use the Up  button and the Down  button to scroll to the options in the list and use the Right  button and the Left  button to change the setting for each one. Once the options in the first menu are selected, scroll to the Continue option and use the Right  button to select it. This brings up a second menu in the Setup Guide. The second menu allows the user to select the amount of Line on Spool, Line Type and Line Weight. The second menu is navigated in the same way as the first. Once happy with the selections, scroll to the Complete Setup option and use the Right  button to select it. After the second menu is complete, the downrigger will bring up information on the Cannon Transducer. Read the information on the Color LCD and then use the Right  button to Select next. This is followed by a message about the Fish Hawk and Humminbird® fish finder. Read the messages and then use the Right  button to select Next. Selecting next on the Humminbird screen completes the Setup Guide.



LANGUAGE - Choose between 1 of 22 languages. The default language is English. Use the Right  button to confirm the language and make sure that the radio button to the right of the desired language is selected.



BATTERY ALARM - Shows an alarm when the battery drops below a certain voltage. The default is set to "off", but can be adjusted between 9.0V and 13.5V. Use the Right  button or the Left  button to edit the sliding scale.



TEMPERATURE - Sets the temperature readings to Fahrenheit or Celsius. Use the Right  button or the Left  button to scroll between the options. The default is set to Fahrenheit.

DEPTH/DISTANCE - Sets the Distance and Depth reading measurements in units of Feet or Meters. Use the Right  button or the Left  button to scroll between the options. The default is set to Feet.

SPEED - Sets the Speed measurements in units of mph (miles per hour), kph (kilometers per hour), or kts (knots). Use the Right  button or the Left  button to scroll between the options. The default is set to mph.

LINE ON SPOOL - Program the downrigger with the amount of Line on the Spool. The spool comes installed with 400 feet of stainless steel line. The Line on the Spool is set to the default of 400 feet. The range can be adjusted from 150 feet, (the minimum suggested amount) to 400. The Line on Spool can be adjusted on 50-foot increments on a sliding scale that can be adjusted using the Right  button or the Left  button.

LINE TYPE - The default Line Type is stainless steel line, but can be set to either Braided, Stainless Steel or Mono. Use the Right  button or the Left  button to scroll between the options.

LINE WEIGHT - The default Line Weight is 50-150lbs, but can be set to either 50-150lbs, 150-200lbs or 200+lbs. Use the Right  button or the Left  button to scroll between the options.

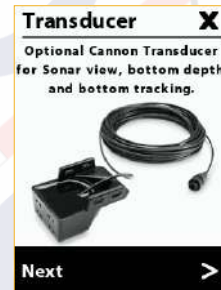
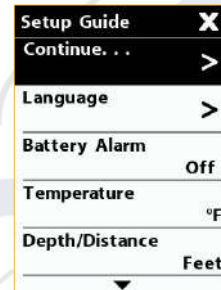

CONNECTING THE DOWNRIGGER



NETWORKING THE OPTIMUM

Through the One-Boat Network™, the Cannon Optimum downrigger can be wirelessly networked to give you total control of your downrigger from anywhere on your boat. If you want to put bait on target, you've got to fish smarter. The new Optimum™ downrigger is positively ingenious. This smart, connected system gives you access to critical trolling data and lets you raise, lower and cycle weights using the full-color LCD display, or your mobile device. No matter where you are on the boat, you're in charge. And the fish won't know what hit them.

The network works by designating one Master downrigger that is paired with all additional equipment through a wireless network. This network includes up to 3 additional Optimum downriggers, a mobile device, the Fish Hawk Lithium Ultra or X4D System and a Cannon transducer. Any one of the Optimum downriggers in the network can be designated as the Master downrigger. The Master downrigger is the central communication hub for the network in which all devices are paired to. Complete the "Installing the Optimum" and "Battery & Wiring" sections of these instructions before setting up the Cannon Optimum downrigger wireless network. Carefully read the information below about how the network functions and then continue to the following sections to pair the additional equipment to the network to set it up for proper control.

THE BLUETOOTH OPTIMUM AND OPTIMUM TS NETWORK

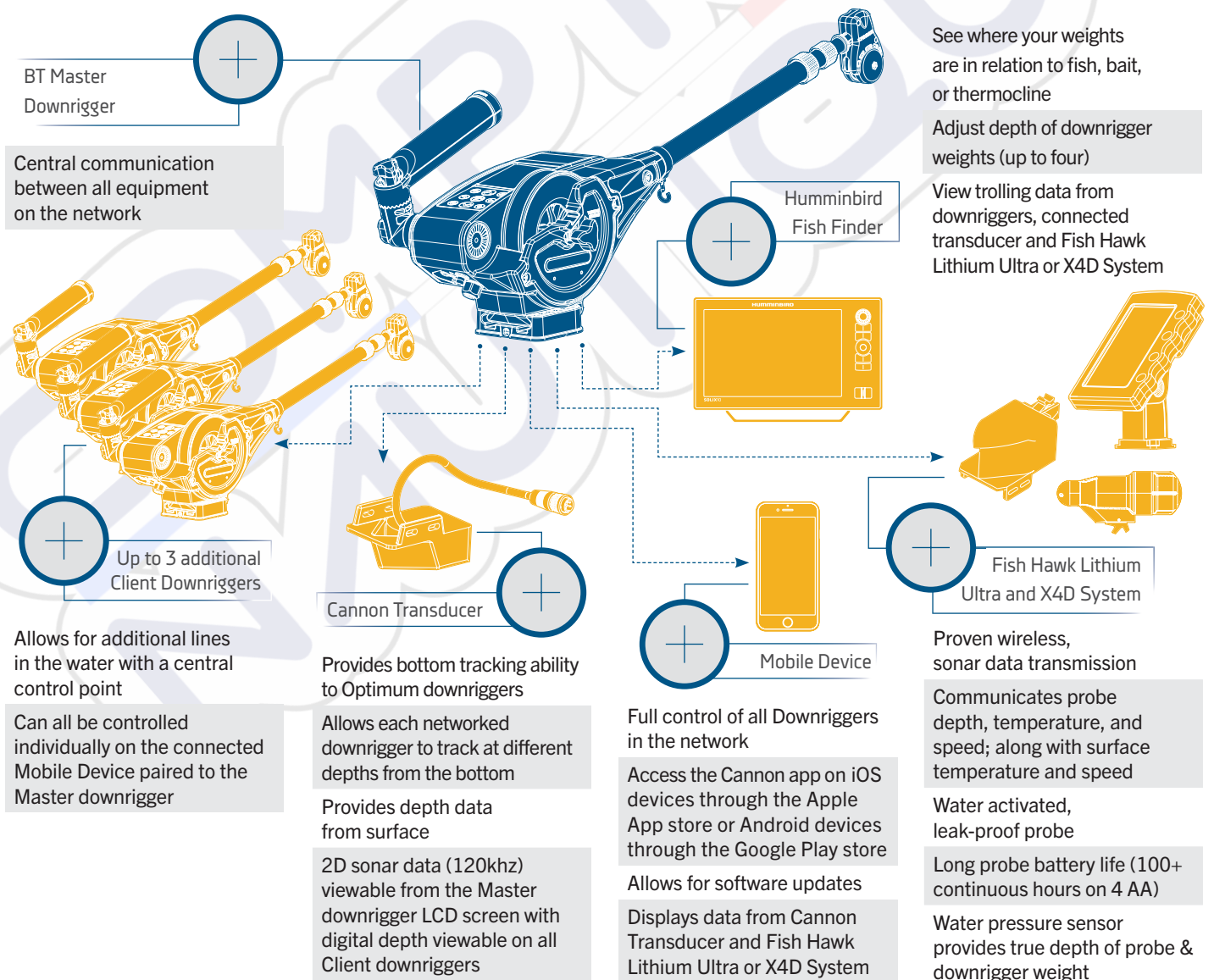

CONNECTING THE DOWNRIGGER

THE MASTER DOWNRIGGER >

The Master downrigger is the Optimum downrigger on the system that is designated to be the central communication hub for the wireless network. Running multiple lines is easier than ever, because complicated wiring is a thing of the past. You can network up to four Optimum downriggers wirelessly. Any downrigger that is added to the network is paired directly to the Master downrigger. The Cannon transducer is plugged into the Master downrigger. The Master downrigger is also paired with the Mobile Device and the Fish Hawk Lithium Ultra or X4D system. The Master downrigger is used to control the communication between the equipment on the network. For example if the downrigger received a software update from the Cannon app, the Master downrigger will communicate the update to any Client downrigger it is paired with. In networks where only one downrigger exists, it will automatically become the Master downrigger if any of the other equipment is connected or paired to it. There cannot be two Master downriggers in a network.

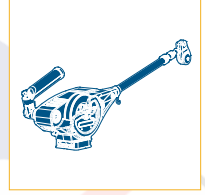

THE CLIENT DOWNRIGGER(S) >

Any downrigger that is paired to the Master downrigger is a Client downrigger. The network can support up to three Client downriggers. The Client downriggers receive information from the Master including software updates from the Cannon app and sonar or probe information from any paired equipment. The network will be interrupted if any additional equipment, besides the Master downrigger are paired to a Client downrigger. Any Client downrigger in the network can be controlled on the Mobile Device paired to the network through the Cannon app.

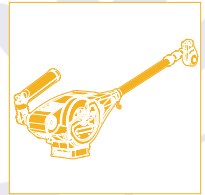

THE CANNON TRANSDUCER >

The Cannon Transducer is the only wired piece of equipment in the Network. The Cannon transducer should only be plugged into the Master downrigger. It delivers sonar data that is displayed on the downrigger Color LCD. The Cannon transducer gives downriggers the ability to use the Bottom Tracking feature and contributes valuable trolling information to the Network. Plugging the Cannon Transducer into any downrigger in the network other than the Master downrigger will interrupt the network.

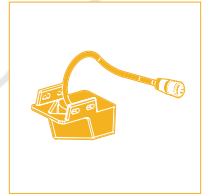

A MOBILE DEVICE >

With the Cannon app on your mobile device, you'll have trolling data at your fingertips and total control of your Optimum downriggers from anywhere on your boat. It even keeps your Optimum software up to date. The Cannon app will only work with Bluetooth® enabled Cannon downriggers. Be sure that you download the correct app as other apps will not work with your Cannon Optimum or Optimum TS downrigger. Launching the app when it is not paired with the Cannon will allow you to try it in Demo Mode. The first time the app is launched, you must agree with the disclaimer in order to continue. Become familiar with the app screens in order to understand how to operate your downrigger(s) with the Cannon app. The Mobile Device should be paired with the Master Downrigger.

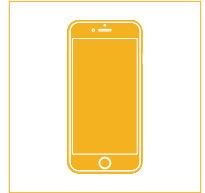

THE FISH HAWK LITHIUM ULTRA AND X4D SYSTEM >

Every Optimum downrigger integrates wirelessly with Fish Hawk Lithium Ultra or X4D System to give you the critical info you need to troll successfully. This system provides the true running depth and speed of your weight, the temperature at the weight, plus surface temperature and speed. Within the wireless Network, the Fish Hawk should only be paired with the Master downrigger.

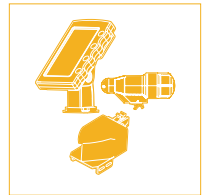

A HUMMINBIRD FISH FINDER >

Optimum downriggers wirelessly network together giving you control of all of your downriggers with push of a button. They connect with your Humminbird® fish finder and your mobile device for total control and to display trolling data. When paired with a Humminbird fish finder, the Optimum can use a Humminbird connected transducer as the source for the Bottom Tracking feature. With the One-Boat Network™, your advanced fishing gear does more than work together. It starts talking to each other wirelessly, to help you find, stay on and land more fish.

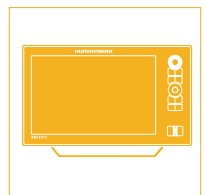

PAIRING A DEVICE TO A SINGLE DOWNRIGGER



PAIRING A DEVICE TO A SINGLE DOWNRIGGER ➤

Cannon offers an app that can be used to control and update the Cannon downrigger using a Bluetooth® enabled device. The Cannon app is available for download on iOS devices through the Apple App store or Android devices through the Google Play store.

The Cannon app can be used to control the downrigger using a device that is paired to the downrigger with a Bluetooth connection. Before pairing the device with the downrigger, the Cannon app should first be successfully downloaded. You can confirm that the app was successfully downloaded by opening it on your device. The Cannon downrigger will only be able to pair with **one** Bluetooth enabled device. It is recommended to review the "Connecting the Downrigger" section of these instructions to understand how the technology works together and understand how downriggers function in a network. If you are pairing a device to a single downrigger, it will automatically become the Master downrigger. If pairing to a series of downriggers, determine which downrigger will be the Master downrigger and then follow steps below and only work with the Master downrigger during this pairing process. The Master downrigger will be referred to as the BT Master.

The Cannon app icon. See the Cannon app section of these instructions (pg 88) for more information on how to control the downrigger on the app.



NOTICE: Your device will only be able to connect to a Cannon and be paired if the device Bluetooth is enabled. Your device will only be able to pair with a Bluetooth enabled Cannon downrigger.

- 1**
 - a. Download the Cannon app on the device you intend to pair with the downrigger. After downloading the app, open it to make sure the download was successful.
 - b. Once the opening screen launches, the app on your device will display a Pairing Guide. The guide will help you pair your Cannon downrigger.
 - c. Turn the Master Cannon downrigger "on", by pressing the Power  button on the keypad.
 - d. Once the downrigger is powered "on", return to the device and select "Continue" from the Pairing Guide screen in the app.

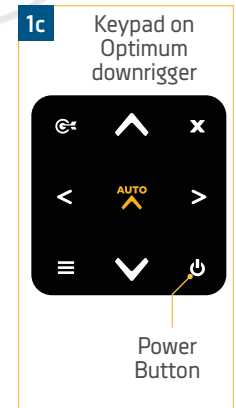
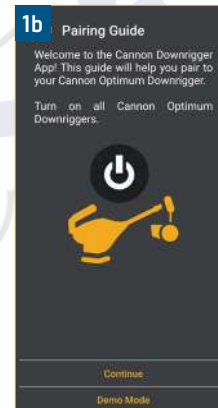

NOTICE: When opening the app if a "Downrigger Not Found" message appears, select "Retry Pairing Setup".



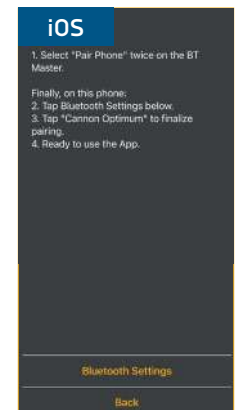
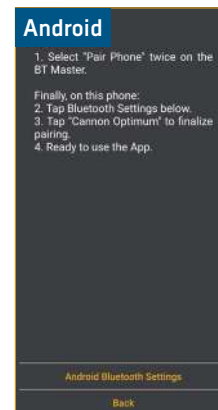

- 2**
 - e. The Cannon app will begin the pairing process by helping to determine which downrigger is going to be assigned the Master downrigger. From the Pairing Guide, an option to Assign a BT Master will appear on the device. Select "Yes, Pair to BT Master" to continue.

NOTICE: The (Bluetooth) BT Master downrigger is the Master downrigger and needs to have all downriggers, phone, and transducer connected to it.



PAIRING A DEVICE TO A SINGLE DOWNRIGGER

3

- f. From the Pairing Guide on the device, select "Bluetooth Settings" from the iOS device or "Android Bluetooth Settings" on the Android device. The Cannon app will redirect the Android device to its Bluetooth Settings and the iOS device to its Settings. On the iOS device open the Bluetooth Settings on the device. Turn Bluetooth on the device "on", and keep your device on the Bluetooth screen.
- g. Return to the downrigger being paired to the device. On the downrigger keypad, press the Menu  button twice to bring up the Settings Menu on the Color LCD.
- h. From the Settings Menu, use the Down  button to scroll to the item listed Bluetooth. Press the Right  button to open the Bluetooth Menu.
- i. From the Bluetooth Menu, use the Down  button to scroll to the Pair Phone option. Press the Right  button to select it.

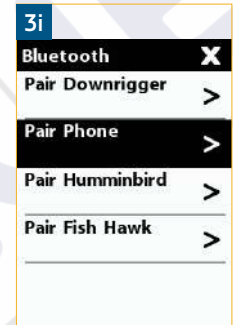
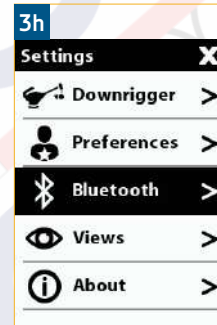
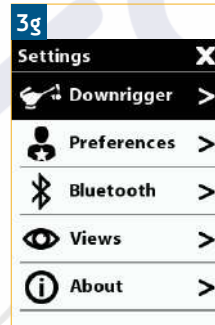
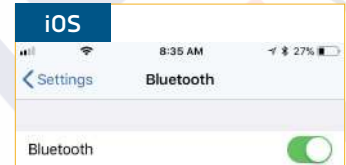
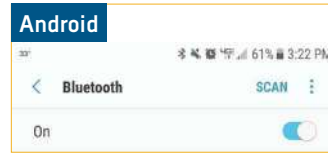

4

- j. When Pair Phone is selected, it brings up the Pair Phone screen on the Color LCD. Press the Right  button on the downrigger keypad to select "Pair Phone". This puts the downrigger in Pairing Mode.
- k. Once in Pairing Mode, the downrigger will display "Pairing Phone...". Return to the mobile device and scan for new Bluetooth devices. If on an Android device, select the Scan button to begin the process on your device. On an iOS device, as soon as the Bluetooth Menu is opened, the scan starts automatically. When the Optimum is recognized by the device, it will appear on the device list. Select the Optimum or Optimum TS from the list of available devices.

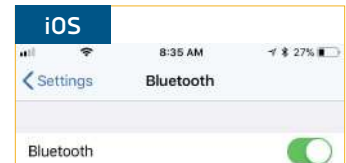
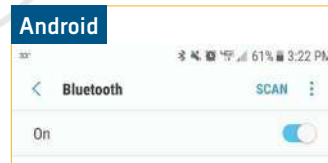

PAIRING A DEVICE TO A SINGLE DOWNRIGGER

5

- l. Once selected on the device list, the downrigger will send a 6 digit passkey to the device.
- m. Check the device to make sure that the pass code on the downrigger Color LCD matches the pass key on the device. Confirm the passkey on the mobile device.

NOTICE: The pass key or code will be different every time the downrigger is paired with a device.

- n. When the pass key is confirmed on the mobile device, the downrigger Color LCD will confirm that the connection was successful.

NOTICE: When the Bluetooth device is scanning for the Optimum, the downrigger must be in Pairing Mode. If the downrigger or the device time out, the process on both will need to be re-initiated.

- o. In order for the device and your Optimum to stay connected, Bluetooth needs to remain "on". Once the device is paired with the Optimum, the device will connect and begin communicating with each other. When the Optimum is paired to the device and communicating with it, the Cannon app will automatically recognize that the downrigger is paired.
- p. If the pair is unsuccessful, return to the Pair Phone Menu on the downrigger and put the downrigger and the device into pairing mode again at the same time and repeat the process.

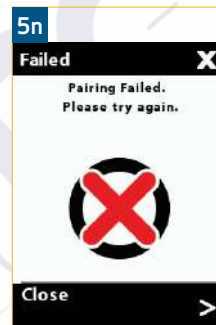
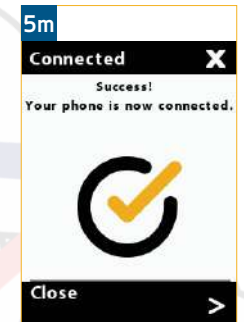
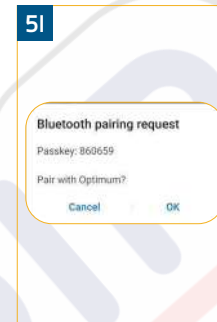

NOTICE: The downrigger will stay in Pairing Mode for 30 seconds. If the pass code is sent to the mobile device, but has not been confirmed on the device, the pair will not be successful. Try the Pairing again and be sure to confirm the pass code before the pairing times out.

NOTICE: When a device is paired with the downrigger, the paired device and downrigger know each other. When a paired device and a downrigger are connected they can actively communicate with each other. In order for the Cannon app to detect the downrigger, it needs to be paired and communicating with the downrigger.







NOTICE: It may take a few moments for your device to connect and the app to respond to the network even after it is connected.

PAIRING TWO DOWNRIGGERS TOGETHER

PAIRING TWO DOWNRIGGERS TOGETHER >

If your boat is set up with multiple downriggers, it is possible to pair up to 4 downriggers together in a network to share information and control the downriggers from a single device. Building a network requires pairing each downrigger with the Master downrigger and allows much of the data to be viewed across the network. Each downrigger paired to the Master downrigger is a Client downrigger. The Master downrigger will be the downrigger in the network that is paired to a device, and is able to be connected to a transducer or Fish Hawk Lithium Ultra or X4D System. It is recommended to review the "Connecting the Downrigger" section of these instructions to understand how the technology works together and understand how downriggers function in a network. To pair two downriggers together follow the instructions below.

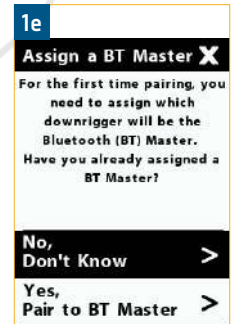
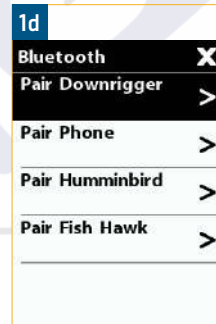
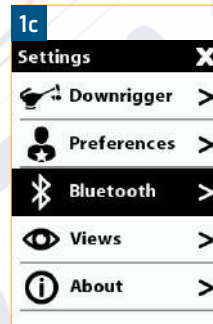
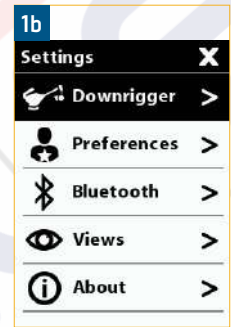
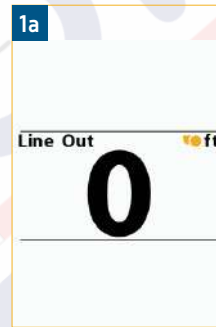
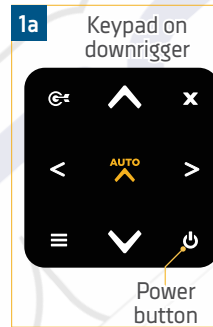

1

- Determine which downrigger will be the Bluetooth Master. Turn both Cannon downriggers "on", by pressing the Power  button on the keypad of each downrigger.
- Then on both downriggers, press the Menu  button twice to bring up the Settings Menu on both Color LCDs.
- From the Settings Menu on both downriggers, use the Down  button to scroll to the item listed Bluetooth. Press the Right  button to open the Bluetooth Menu.
- From the Bluetooth Menu on both downriggers, use the Down  button to scroll to the Pair Downrigger option. Press the Right  button to continue.
- Both the Master and Client downrigger will display an Assign a BT Master on the Display Screen.



NOTICE: The Master downrigger is the downrigger that a mobile device, all downriggers and accessories, such as the Cannon transducer, Humminbird fish finder and Fish Hawk, will be paired to. The Client downrigger is the downrigger that will be paired to a Master downrigger.

2

- From the downrigger that will be assigned to the BT Master, select "No, Don't Know" by pressing the Right  button.
- From the Client downrigger, use the Down  button to scroll to the "Yes, Pair to BT Master" option. Press the Right  button to continue.

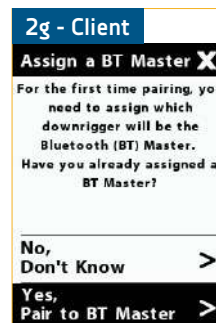
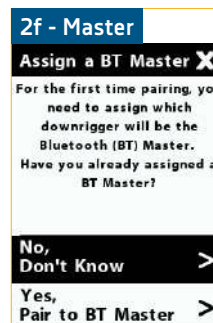



PAIRING TWO DOWNRIGGERS TOGETHER

3

h. On the BT Master downrigger, the Color LCD will follow several on-screen prompts outlining criteria for the BT Master/Master downrigger. They include:

- The BT Master shares data to all the other downriggers in the network.
- An optional Fish Hawk probe can only be paired to the BT Master.
- The Cannon mobile app can only be paired to the BT Master.
- Cannon Transducer can only be connected to the BT Master.
- Compatible Humminbird can only be connected to the BT Master.

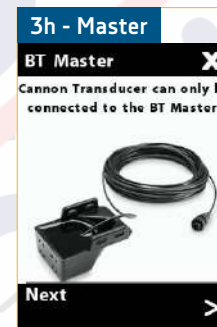
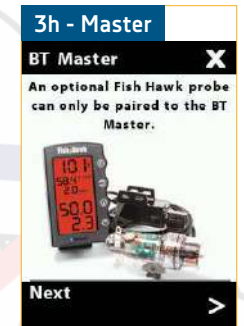
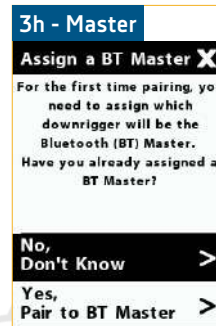

Press the Right  button to read and continue through these message screens.

i. The final screen will ask, "Which downrigger do you want to assign as the BT Master?" Press the Right  button to select "This downrigger".



PAIRING TWO DOWNRIGGERS TOGETHER

4

- j. On the Master downrigger, a Pair Downrigger screen will be on the Color LCD. Press the Right  button to select it. The Color LCD will bring up a "Pairing Downrigger...." message. The Master downrigger is now actively trying to pair with the Client Downrigger.
- k. On the Client downrigger, a Pair to BT Master screen will be on the Color LCD. Press the Right  button to select it. The Color LCD will bring up a "Pairing Downrigger...." message. When this message displays, the Client downrigger is actively trying to pair to the Master downrigger.
- l. Both downriggers will stay in Pairing Mode for 30 seconds. When they successfully connect, both downriggers will display a Connected message.



NOTICE: When two downriggers are paired to each other, they will be listed in each other's Device List under the Bluetooth Menu. When two Downriggers are paired, they know each other. In order for the downriggers to detect each other they need to be paired and communicating. When the downriggers are powered "on" and have been paired together, they can connect. When the downriggers are connected they can actively communicate. When the downriggers are powered "off" and have been paired together, they will know each other, but will not be actively communicating.

5

- m. You can also confirm that the downriggers have paired to each other by finding them on the Device List under the Bluetooth Menu. The Master downrigger will appear on the Device List with a box around the Bluetooth icon.

NOTICE: The options listed in the Bluetooth Menu will be different once a downrigger is paired to another downrigger. On the Master downrigger, the option to pair with other downriggers, a device or a Fish Hawk will still be available. On a Client downrigger, the Bluetooth Menu will only allow you to view the Device List or Forget BT Master.

- n. To pair additional downriggers to the Master downrigger, repeat the process with the Master downrigger and the new Client downrigger to be added to the network.

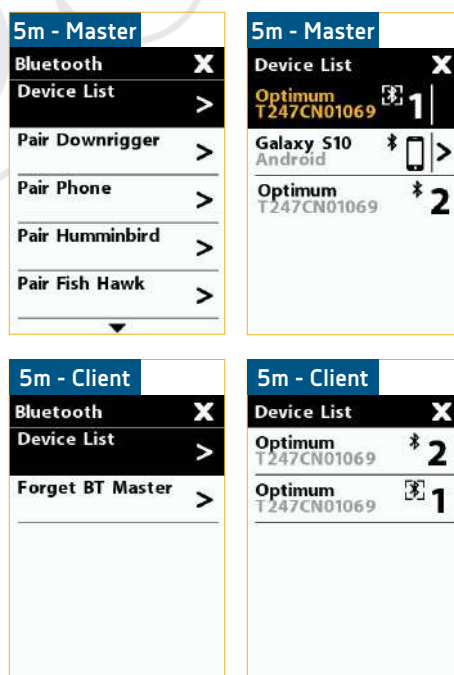

PAIRING THE MASTER DOWNRIGGER TO A HUMMINBIRD



PAIRING THE MASTER DOWNRIGGER TO A HUMMINBIRD

Pairing a Humminbird to your Master downrigger will allow your downrigger to display features such as Bottom Tracking and give you remote control of your downriggers from the Humminbird display. It is important to install the latest software update on your Humminbird fish finder to enable Cannon features. For the SOLIX Series version 3.710 and later is required and for the HELIX G2N/G3N Series version 2.250 and later is required. To check for compatibility or update your fish finder, please visit humminbird.com for details. The Humminbird must be paired with the Master downrigger. To pair a Humminbird, follow the steps below:

1

- a. Make sure the Master downrigger is turned "on", by pressing the Power  button on the downrigger keypad.

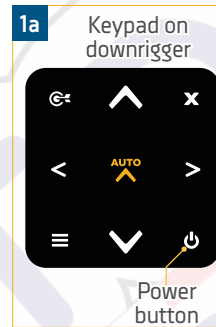

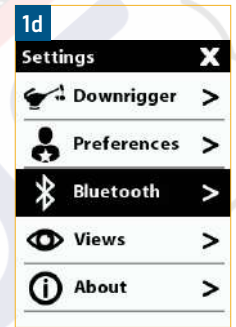
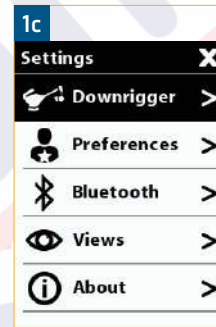

- b. Power on the Humminbird fish finder "on".

On a Solix, press the HOME key. Select the Bluetooth tool. Under Cannon, select Cannon Settings. Select Pair Device.





On a Helix, press the MENU key twice. Select the Accessories tab. Select Bluetooth Cannon. Press the RIGHT Cursor key. Select Pair Device. Press the RIGHT Cursor key.

- c. On the Master downrigger, press the Menu  button twice to bring up the Settings Menu on the Color LCD.
- d. From the Settings Menu, use the Down  button to scroll to the item listed Bluetooth. Press the Right  button to open the Bluetooth Menu.

NOTICE: For more specific instructions on how to Pair and operate your Cannon downrigger on your Humminbird fish finder, please refer to the Owner's Manual. It can be found online at humminbird.com.

2

- e. From the Bluetooth Menu, use the Down  button to scroll to the Pair Humminbird option. Press the Right  button to continue.
- f. The Color LCD will bring up a "Pair Humminbird" screen. Use the Right  button to confirm that you want to pair with the Humminbird.
- g. While the downrigger is actively searching for the Humminbird, a "Pairing..." message will show on the Color LCD. Once the pairing is successful, a confirmation screen will appear and the Humminbird is successfully paired.

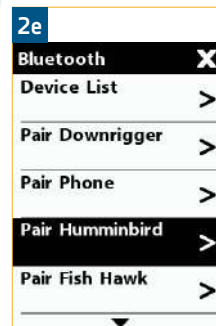

PAIRING THE MASTER DOWNRIGGER TO A FISH HAWK

PAIRING THE MASTER DOWNRIGGER TO A FISH HAWK



Pairing a Fish Hawk™ Lithium Ultra or X4D System to your Master downrigger will allow your downrigger to display true running depth and the speed of your weight, the temperature at the weight, plus surface temperature and speed. The Fish Hawk must be paired with the Master downrigger. To pair a Fish Hawk, follow the steps below:

1

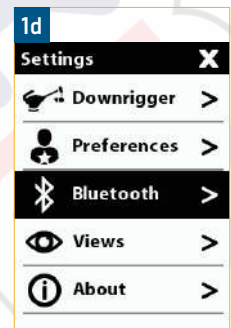
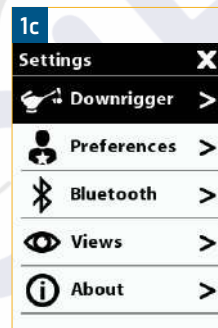
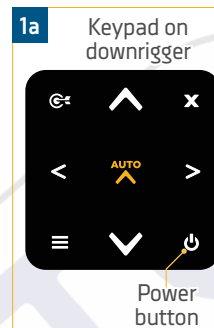

- Make sure the Master downrigger is turned "on", by pressing the Power  button on the downrigger keypad.
- Power on the Fish Hawk Display. Once powered on the Display will continuously transmit and wait for another device to be connected.



NOTICE: The Fish Hawk Lithium Ultra and X4D Systems must be paired with the Master downrigger. The Fish Hawk Lithium Ultra and X4D Systems are the ONLY compatible Fish Hawk Systems to pair with the downrigger. Other Fish Hawk Systems will not be compatible with the Optimum or Optimum TS downrigger.

- On the Master downrigger, press the Menu  button twice to bring up the Settings Menu on the Color LCD.
- From the Settings Menu, use the Down  button to scroll to the item listed Bluetooth. Press the Right  button to open the Bluetooth Menu.

2

- From the Bluetooth Menu, use the Down  button to scroll to the Pair Fish Hawk option. Press the Right  button to continue.
- The Color LCD will bring up a "Pair Fish Hawk" screen. Use the Right  button to confirm that you want to pair with the Fish Hawk.
- While the downrigger is actively searching for the Fish Hawk, a "Pairing Fish Hawk..." message will show on the Color LCD. Once the pairing is successful, a confirmation screen will appear and the Fish Hawk is successfully paired.

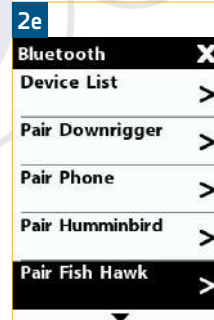

NOTICE: Once the downrigger is paired to the Fish Hawk, both need to be powered on in order for them to communicate. If you wish to remove the Fish Hawk to rebuild the network, or assign a new Master downrigger, you must clear the network on the downrigger and re-pair the Fish Hawk with the new Master downrigger.



FORGETTING A DOWNRIGGER ON A DEVICE



FORGETTING A DOWNRIGGER ON A DEVICE >

Once an Optimum is paired to a device, it will remember the downrigger, even if the device and the downrigger are not actively communicating. In some cases, it may be necessary to clear the memory of the device and forget any paired downrigger. To do this, use the Bluetooth settings on the device.

1

- a. Open the Bluetooth settings on the device.
- b. A list of paired devices will appear. The appearance of the list from an Android to an iOS device will look different.
- c. On an Android device, select the Settings  icon next to the device in the list of Paired Devices. When the next screen appears, find the option to Unpair the device and select it.
- d. On an iOS device, select the “i”  icon next to the device in the list of My Devices. When the next Screen appears, find the option to Forget this Device and select it.
- e. Once the device is unpaired or forgotten, the device is no longer paired or communicating with the device and will not be visible to the Cannon app or the device.

NOTICE: Images are for illustrative purposes and may vary based on your device and operating system.

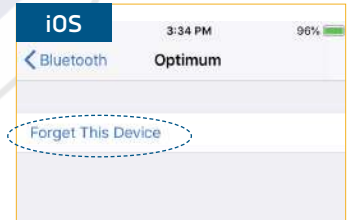
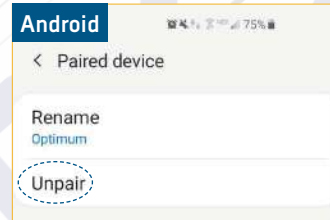
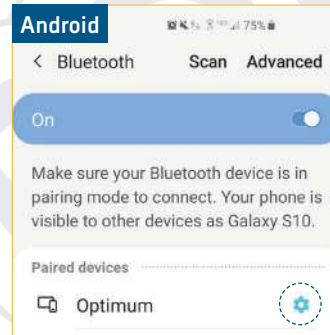

FORGETTING A DEVICE, HUMMINBIRD, FISH HAWK OR DOWNRIGGER ON A DOWNRIGGER

FORGETTING A DEVICE, HUMMINBIRD, FISH HAWK OR DOWNRIGGER ON A DOWNRIGGER >

Once a device is paired to a Optimum, it will remember the device, even if the device and the downrigger are not actively communicating. This is also true for two downriggers paired together or a downrigger paired to a Humminbird fish finder or Fish Hawk Lithium Ultra or X4D System. In some cases, it may be necessary to clear the memory of the downrigger and forget any paired devices or downriggers. To do this, use the Settings Menu on the downrigger.

NOTICE: To remove a specific device, Fish Hawk, Humminbird or downrigger from the downrigger network, remove them one at a time by using the options in the Device List. To remove everything paired to a specific downrigger, follow the "Clearing the Downrigger Network" section of these instructions.

1

- Turn the Master downrigger "on", by pressing the Power  button on the keypad.
- On the downrigger keypad, press the Menu  button twice to bring up the Settings Menu on the Color LCD.
- From the Settings Menu, use the Down  button to scroll to the item listed Bluetooth. Press the Right  button to open the Bluetooth Menu.
- From the Bluetooth Menu, use the Down  button to scroll to the Device List option. Press the Right  button to continue.
- From the Device List, select the device, Humminbird, Fish Hawk or downrigger that the downrigger should forget. Use the Down  button or the Up  button to scroll to it in the list. Use the Right  button to select it.
- Once selected, the downrigger Color LCD screen will bring up a Forget Phone, Forget Humminbird, Forget Fish Hawk or Forget Downrigger screen. Use the Right  button to Confirm that the downrigger should forget the equipment selected.
- The downrigger will flash a message Phone Removed, Humminbird Removed, Fish Hawk Removed or Downrigger Removed to confirm it was deleted from memory.

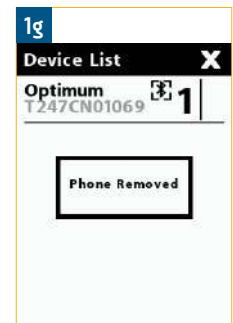
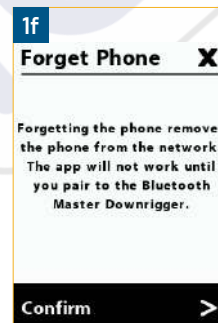
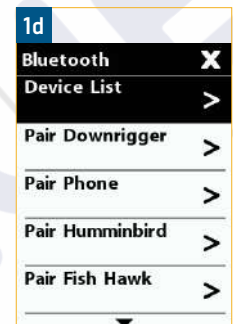
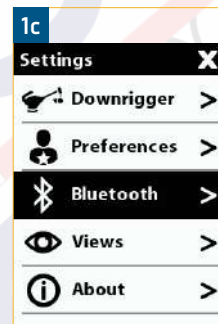
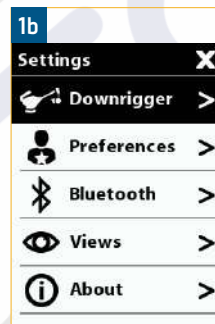

NOTICE: Forgetting the phone, Humminbird, Fish Hawk or downrigger removes them from the network. The Cannon app will not work until you pair the device with the Cannon app to the Bluetooth Master downrigger.

NOTICE: To exit the menu, press the Close  button on the downrigger keypad.

CLEARING THE DOWNRIGGER NETWORK





CLEARING THE DOWNRIGGER NETWORK ➤

Once a device or downrigger is paired to a Optimum, it will remember them, even if the device or downrigger are not actively communicating with the downrigger they are paired with. In some cases, it may be necessary to clear the memory of the Master downrigger and forget any paired devices and downriggers on the Fish Hawk. To do this, use the Settings Menu on the Master downrigger. Devices on a Cannon network may include the Fish Hawk Lithium Ultra or X4D System, another downrigger, or a paired device. Restoring the network on the downrigger is helpful when creating a new network or assigning a new Bluetooth Master. Restoring the network helps to clear everything that is paired all at once. If you wish to clear only one specific paired item on the network, use the instructions for "Forgetting a Device, Humminbird, Fish Hawk or Downrigger on a Downrigger" section of these instructions.

1

- a. Turn the Master downrigger "on", by pressing the Power button on the keypad.
- b. On the downrigger keypad, press the Menu button twice to bring up the Settings Menu on the Color LCD.
- c. From the Settings Menu, use the Down button to scroll to the item listed Bluetooth. Press the Right button to open the Bluetooth Menu.
- d. From the Bluetooth Menu, use the Down button to scroll to the Restore Network option. Press the Right button to continue.
- e. Once selected, the downrigger Color LCD screen brings up a Restore Network screen. Use the Right button to Confirm that the downrigger should forget all devices on the network.
- f. The downrigger will flash a message Network Restored to confirm that all devices and downriggers were deleted from memory.

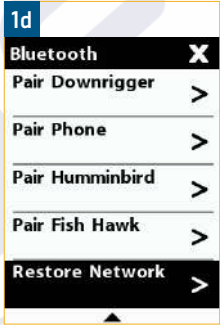
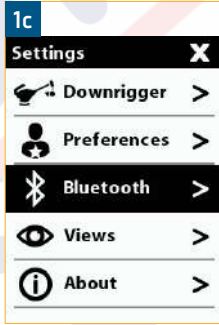
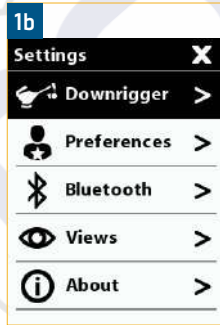







CLEARING THE MASTER DOWNRIGGER FROM THE CLIENT DOWNRIGGER

CLEARING THE MASTER DOWNRIGGER FROM THE CLIENT DOWNRIGGER

It may be necessary to remove a Client downrigger from the network. This can be accomplished without interrupting the rest of the network simply by removing the Master downrigger from the Client downrigger. This may be helpful when moving one Client downrigger to a different network, or replacing one downrigger in an existing network with a new one.

1

- Turn the Client downrigger "on", by pressing the Power  button on the keypad.
- On the downrigger keypad, press the Menu  button twice to bring up the Settings Menu on the Color LCD.
- From the Settings Menu, use the Down  button to scroll to the item listed Bluetooth. Press the Right  button to open the Bluetooth Menu.
- From the Bluetooth Menu, use the Down  button to scroll to the Forget BT Master option. Press the Right  button to continue.
- Once selected, the downrigger Color LCD screen bring up a Forget BT Master screen. Use the Right  button to Confirm that the downrigger should forget the Master downrigger.
- The downrigger will flash a message Downrigger Removed to confirm that it was deleted from memory.

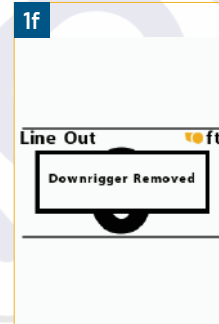
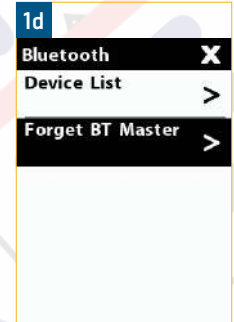
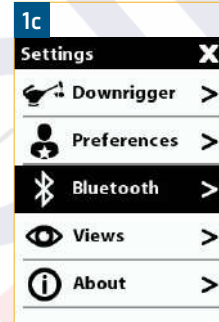
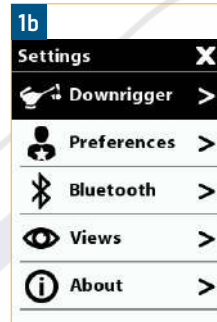

NOTICE: Forgetting the Master downrigger will remove this downrigger from the network.

UPDATING THE CANNON APP & DOWNRIGGERS IN A NETWORK



UPDATING THE CANNON APP & DOWNRIGGERS IN A NETWORK

Any updates to the Optimum downrigger will be made through the Cannon app from a paired Mobile Device. If the downrigger is not connected to a device, refer to the "Pairing a Device to a Single Downrigger" section in these instructions. Before updating the downrigger, check for updates to the Cannon app on the Mobile Device by looking for updates on iOS devices through the Apple App store or Android devices through the Google Play store. Any updates to the Cannon app need to be completed before continuing to check in the app for updates to the downrigger software. Be sure that the downrigger is paired and communication with the Mobile Device and that all downriggers are powered "on". When updating a downrigger that is paired to other downriggers, it is best to send the update to the Master downrigger. The Master downrigger will push the update to the paired Client downriggers it is networked with. See the Cannon app section of these instructions (pg 85) for more information on how to use the Cannon app.

1

- a. Open the Cannon app on the Mobile Device.

NOTICE: If you are not connected to the downriggers, you may select "Demo Mode" in the Cannon app to reach the Software Updates option. You may then select the grayed out Optimum to identify current installed version or newest available update.

- b. From the app, open the Menu by pressing the Menu  button. The Menu button is found in the upper left corner of the app.
- c. From the Menu, select the Software Update option.



2

- d. In the Software Update screen, the app will identify if an update is available. It will also list all downriggers in the network and what version of software they contain. If an update is identified, it will display a "Download" button. Select the update button to Download the update to the Cannon app.
- e. If the update to the Cannon app contains a software update for the Cannon Optimum downrigger, the Software Update screen will then display a "Transfer" button. Double check that the Optimum downriggers are powered on and all connected to the network.

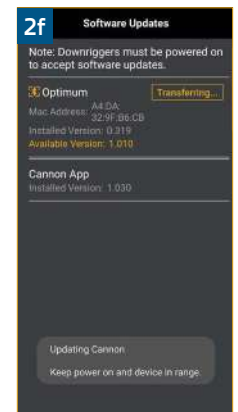
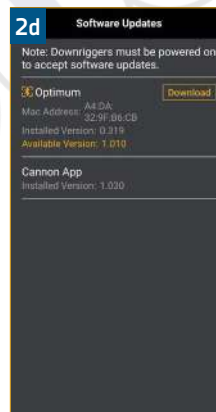

NOTICE: Downriggers must be powered on to accept software updates.

- f. Selecting the "Transfer" button will transfer the software update for the Optimum to the downrigger.

NOTICE: Downloading the update to the mobile device requires to be connected to WiFi or cellular data. Once the new update has downloaded to the device, transferring the update to the downrigger can be done without WiFi or cellular data, through the network.

UPDATING THE CANNON APP & DOWNRIGGERS IN A NETWORK

3

- g. Both the Cannon app and the downrigger will alert that the software update is transferring to the downrigger.
- h. When the update has completed transferring to the downrigger(s), the downrigger(s) will reboot. The Master downrigger will communicate the update transferred from the Cannon app to all paired Client downriggers.

NOTICE: Do not interrupt power during software update. Downrigger will reboot once installation is complete.

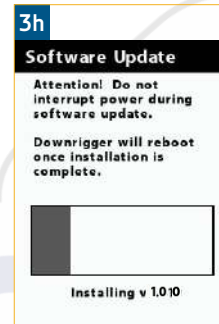
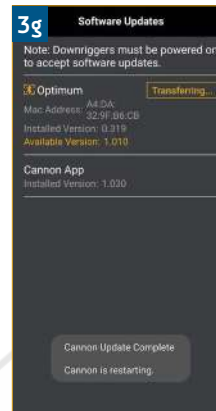

FISHING WITH THE DOWNRIGGER

CONNECTING THE CANNON TRANSDUCER >

The Cannon Transducer (Item #1491072) is an optional accessory available for your Optimum and Optimum TS downrigger. By installing the Transducer, the Optimum is able to display water depth and use the Bottom Track feature. Proper transducer installation is critical to the performance of the Bottom Tracking feature. For best results, follow all mounting instructions included with the Cannon Transducer carefully, before beginning the directions below, to connect the Transducer to the Optimum downrigger.

NOTICE: Power to the Optimum should be turned "off" before installing the Cannon Transducer.

Once the Transducer is installed according to the provided instructions, route the Transducer Cable to your downrigger. When routing the Transducer Cable give consideration to the following:

- Route the Transducer Cable in a way that will not cause damage to the cable jacket.
- Keep the Transducer Cable away from ignition, tachometer, alternator and other electrical wiring to prevent interference.
- Do not cut, splice or shorten the Transducer Cable. Coil the excess cable into a loop like a figure 8 and loosely secure it in place where it will not be a tripping hazard or be damaged from external forces. Do not kink the cables.
- Connecting the Cannon Transducer to a Bluetooth enabled downrigger that is networked to one or more downriggers will make it the Master downrigger. If a Master downrigger already exists in the downrigger network, connecting the transducer to any other downrigger in the network, except for an existing Master downrigger will disrupt the network. See the "Connecting the Downrigger" section of these instructions for more information on downrigger connectivity and Master downriggers.



WARNING

Cutting, splicing or shortening of the Transducer Cable, including removing the connector, voids the product warranty.

1

- a. Before connecting the Cannon Transducer to the Optimum, make sure that the Optimum downrigger is turned "off".

NOTICE: The Transducer Cable should be connected before the downrigger is powered "on".

- b. Review the Transducer Cable routing considerations above and route the Transducer Cable in the boat so that it reaches the downrigger following the guidelines provided.
- c. Locate the Transducer Input on the bottom side of the downrigger body. The Transducer Input is located just to the left of where the Power Cable exits the downrigger body. The Transducer Input is covered by a tethered Cap to keep the downrigger body water tight. Remove the Cap so that the Transducer Cable from the Cannon Transducer can be plugged in.
- d. Examine the Transducer Input and the end of the Transducer Cable coming from the Cannon Transducer. Notice how the connection is keyed. Align the keys and press the connection firmly together.

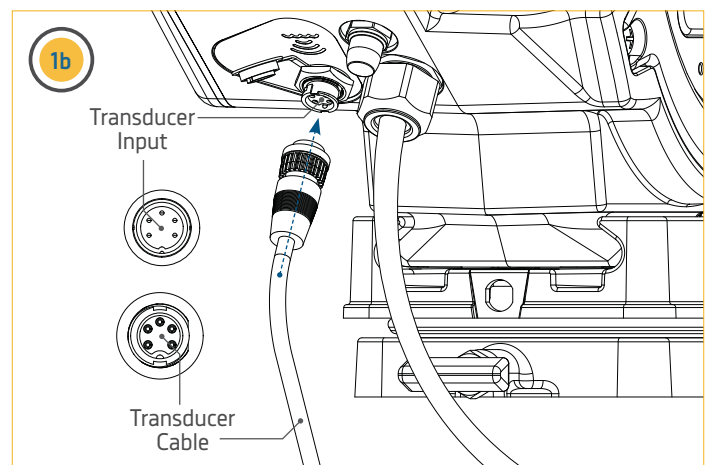
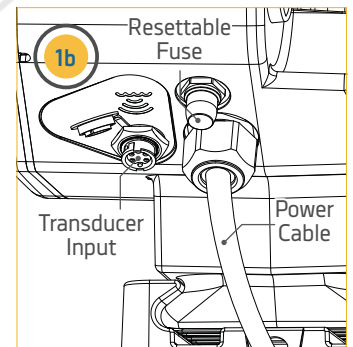
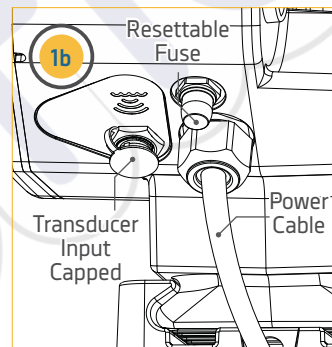

ATTACHING THE SNAP ASSEMBLY WITH INSULATOR

ATTACHING THE SNAP ASSEMBLY WITH INSULATOR >

The Snap Assembly with Insulator is used to break any electrical connection between the downrigger and the water. This insulator is used with the Short Stop and Positive Ion Control features of the downrigger.

Short Stop is a Cannon exclusive feature that automatically stops the weight at the water's surface, preventing the lift motor from raising it into the pulley at the end of the boom. When the downrigger line is in the water, a small electrical current flows between the line and grounded metal boat components in the water. When the line clears the water, the current flow stops. The Short Stop system senses this interruption and turns off the motor. The trolling weight insulator is used to break the line contact to the water while the weight is still in the water. Stopping the weight at water level eliminates the line strain caused by a bouncing weight or a weight hitting the boom end and it also prevents the weight from swinging into the boat hull. This feature comes on all Cannon electric downriggers and requires the boat to be properly grounded and the use of an electrically conductive cable such as stainless steel. This feature will not work with mono or braided lines.

Positive Ion Control is a feature that is based on the principle that applying a low voltage positive electrical field into the water where you're fishing will attract fish and increase your chances to catch more fish. Since fish are attracted by a slight positive charge and repelled by a strong positive or negative charge, generating and controlling the correct charge can be critical to the success of your fishing. When PIC is turned on and the downrigger is spooled with line that can conduct an electrical current, the insulator helps to break the connection with the water so that the positive electrical field emitting from the downrigger line is broken.

1

Item(s) needed:



#34 x 1

- Before attaching the Snap Assembly with Insulator, complete the Terminating the Downrigger section of these instructions. The properly terminated line can have a weight attached directly to it.
- To begin, make sure that a weight is not attached to the Snap Swivel. Then take the Snap Assembly with Insulator (Item #34) and attach it to the Snap Swivel.
- The Weight can then be attached to the Snap Assembly with Insulator.

NOTICE: In some cases it may be necessary to use two Snap Assembly with Insulators connected consecutively to break the electrical connection with the water.

CAUTION

Do not overload the downrigger. It is designed to retrieve a maximum of 20 lb. weights only.

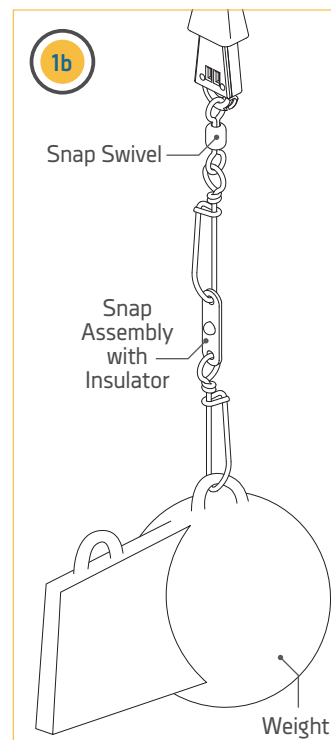
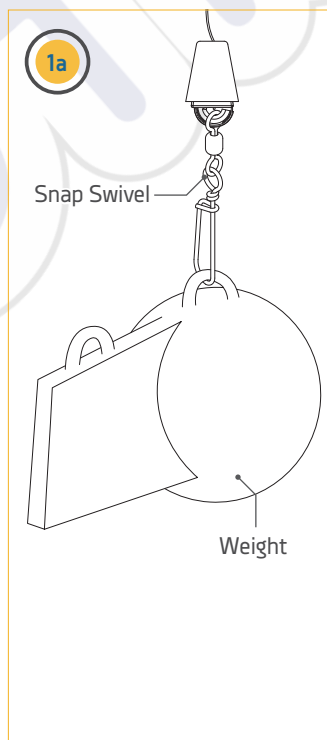

ATTACHING A LINE RELEASE



ATTACHING A LINE RELEASE >

The last step in prepping the downrigger for fishing is to attach a Line Release. To attach the Line Release, first attach a Cannon Weight and then follow the steps below:



To watch a video on how to attach a Line Release, follow the link on-line at <https://youtu.be/qpONbVgbbt8>

1

Item(s) needed:

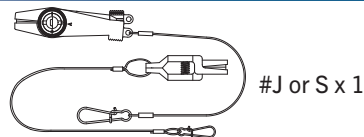

- a. Take the Release (Item #J or #S) and attach the Snap Lock end of the Line Release to the Weight.
- b. Release some line from the fishing rod and reel so that the lure is anywhere from 5 to 100 feet behind the boat. Determine a distance for the line from the fishing pole to drop back from the Weight and select a point for the line to be attached.
- c. Twist a loop in the fishing line at the point that the line would be attached. Attach the line from the fishing rod firmly into the Clamp of the Line Release at the loop created in the fishing line.
- d. Click through a series of increasing tension settings on the Clamp. The Line Release can be used with any test line on salt or fresh water and may be adjusted from 2 to 22 pounds of grip tension on the line.
- e. Once the Line Release is attached to the fishing line, make sure the Fishing Rod is held securely or placed in a holder and open the reel so that line can draw out.
- f. Then set the downrigger depth to lower the Weight to the desired depth in the water.
- g. Once the downrigger Weight is at the desired depth, reel up the slack on the fishing line so that your fishing rod has a slight bend in it. When a fish strikes the lure, the line will separate from the Line Release. Then the fishing line will be free to fight the fish and bring it up on the rod and reel.

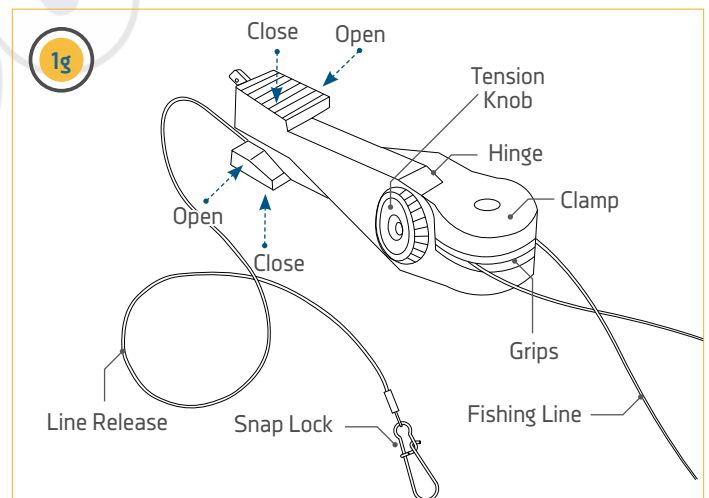
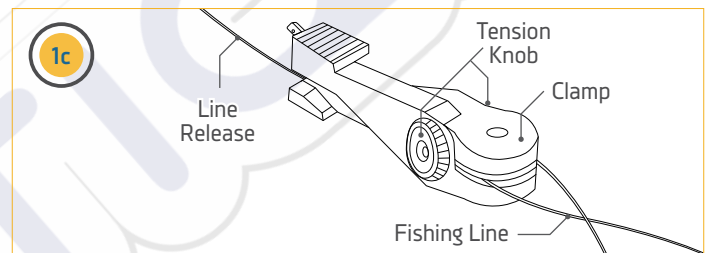
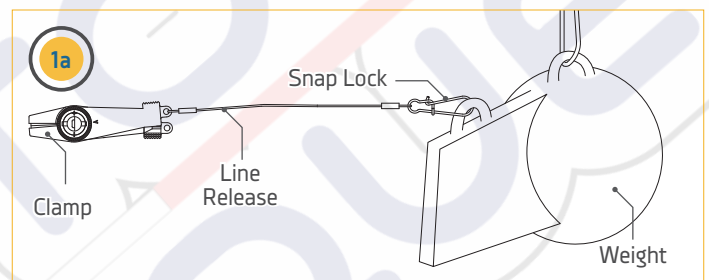

NOTICE: To change the Freshwater Line Release tension, turn the Tension Knob towards (+) to increase or (-) to decrease. Tension also may vary according to where the line is placed in the Grips of the Clamp. Higher tension is on the line if it is set back toward the Hinge, and lower if set closer to the opening. To open the Line Release, spread the Release Arms with thumb and forefinger applying pressure to the sides.

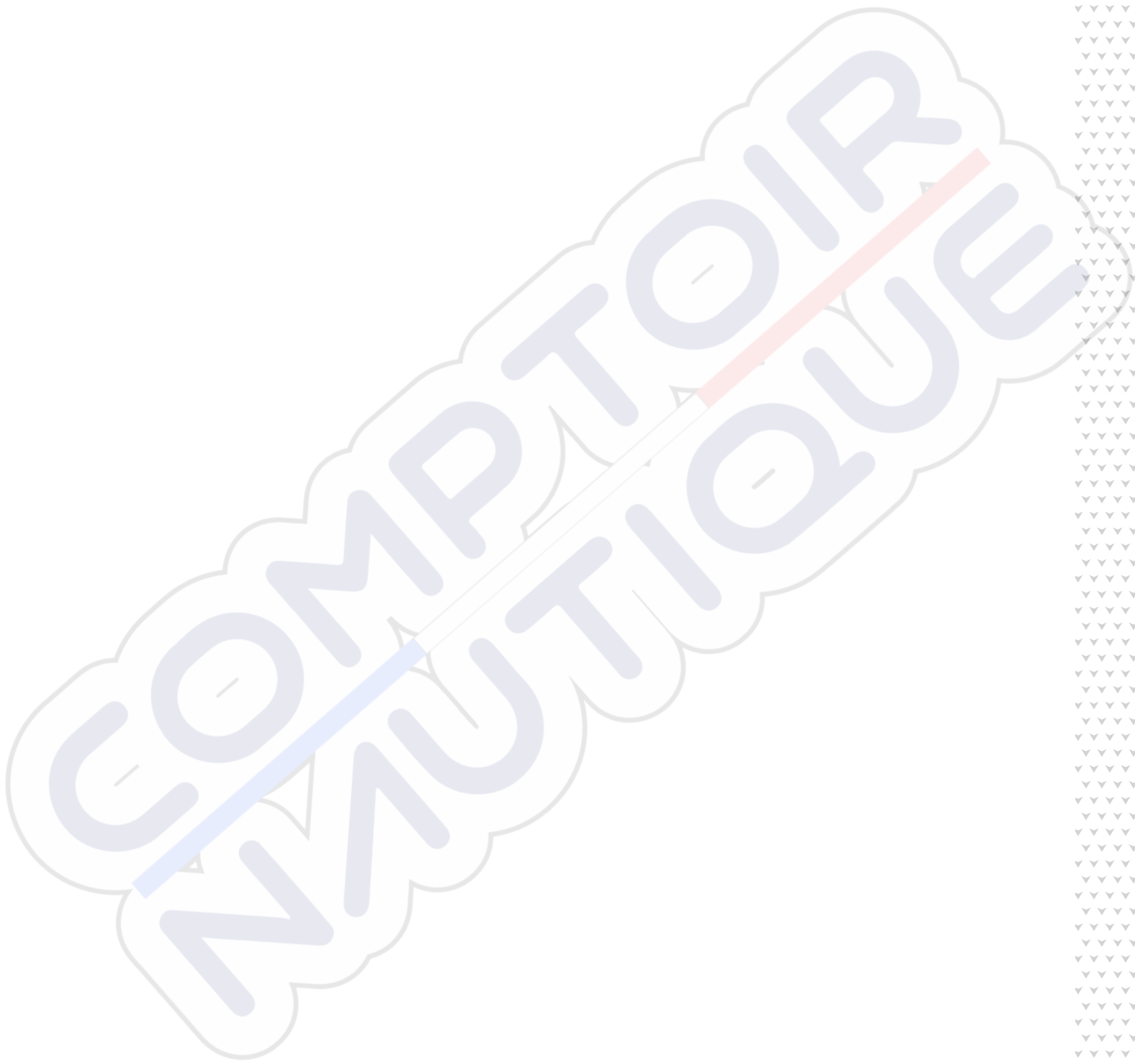

This completes the installation of your Optimum. A complete Owner's Manual can be downloaded at cannondownriggers.com.

RECOMMENDED ACCESSORIES

ROD HOLDERS & TRACK SYSTEMS

Incredible versatile rod holders, rock-solid bases and plates. It's everything you need to rig your boat up to fit the way you fish - and you can mount it all up on our track system, which features interchangeable components made of high-strength aluminum.



Dual Axis Adjustable Rod Holder



Aluminum Mount Track



Swivel Base Pedestal

MOUNTS

Rig it up and reel 'em in with a variety of mounting options suited to fit the way you fish.



Swivel Base



Deck Plate



Gimbal Mount

LINE RELEASES & WEIGHTS

We offer a wide variety of downrigger accessories designed to give you the best fishing experience:



- Uni-Line Release
- Uni-Stacker Release
- 4 to 12 lb. weights

For a complete listing of Cannon accessories, visit cannondownriggers.com



cannondownriggers.com



Cannon Consumer & Technical Service
Johnson Outdoors Marine Electronics, Inc.
PO Box 8129
Mankato, MN 56002-8129

121 Power Drive
Mankato, MN 56001
Phone (800) 227-6433
Fax (800) 527-4464



©2025 Johnson Outdoors Marine Electronics, Inc.
All rights reserved.